

# ProWINCH



## Assembly & Operating Instructions **SERIES PWY90 s/xs**



INTELLECTUAL PROPERTY REGISTRY N° 189487  
ANY REPRODUCTION IS FORBIDDEN  
ALL RIGHTS RESERVED ARE PROPERTY OF THE AUTHOR, ® PROWINCH 2014 - V7.0  
PROWINCH LLC COMPANY WITH QUALITY MANAGEMENT SYSTEM



## **PROWINCH®**

---

Prowinch® LLC states that has given the customer all possible safety warnings related to the acquired equipment, so, in behalf of that, does not assume any responsibility for any problems or injuries that the customer or third parties may suffer if caused by not complying direct or indirectly the operation and safety instructions indicated in this User's Manual with the warnings associated with the acquired unit.

Prowinch® LLC will not respond for any accidents or harm done to persons or the property that may result as a consequence of the wrong use of this equipment.

Prowinch® LLC will not assume any responsibility regarding the use of third party recommendations and does not offer any warranty for them. Any other recommendation does not have any priority over the safety norms in force at customers site.

In case of use of the equipment warranty, Prowinch® LLC will only execute it and respond if the customer has valid proof of complying with all warnings and safety instructions indicated in this user's manual

The information contained in this manual may have technical errors over which Prowinch® LLC does not assume any responsibility.

This user's manual is subject to changes without customers permission or prior advise.

Always check [www.prowinch.com](http://www.prowinch.com) for the latest information regarding this equipment.



INTRODUCTION .....	4
SAFETY WARNINGS AND PRECAUTIONS .....	5
WINCH WARNINGS AND PRECAUTIONS .....	6
UNPACKING .....	7
INSTALLATION .....	7
OPERATION .....	13
WINCH ACCESSORIES YOU WILL NEED .....	15
RIGGING TECHNIQUES	
LUBRICATION .....	16
CABLE ASSEMBLY REPLACEMENT .....	
TROUBLE SHOOTING .....	17
WINCH ASSEMBLY DRAWING PWY90s SERIES .....	18
WINCH PARTS LIST PWY90s SERIES .....	19
WINCH ASSEMBLY DRAWING PWY90xs SERIES .....	20
WINCH PARTS LIST PWY90xs SERIES .....	21
Outline dimensional drawing .....	22
SPECIFICATION (PWY90sU/A U3/A3) .....	24
SPECIFICATION (PWY90sU1/A1 U2/A2) .....	25
SPECIFICATION (PWY90sYP/Y3P) .....	26
SPECIFICATION (PWY90sY1P/Y2P) .....	27
SPECIFICATION (PWY90sYD/Y3D) .....	28
SPECIFICATION (PWY90sY1D/Y2D) .....	29
SPECIFICATION (PWY90xsYP) .....	30
SPECIFICATION (PWY90xsYD) .....	31
WARRANTY .....	32



## INTRODUCTION

20000lb series winches are Prowinch totally new products up to the present in the world; each one owns several invention patents of Prowinch;

Congratulations on your purchase of a highest class advanced powerful two speed winch. We design and build winches to strict specifications and with proper use and maintenance should bring you years of satisfying service.



### WARNING

Read, study and follow all instructions before operating this device.  
Failure to heed these instructions may result in personal injury and/or property damage.

Your winch can develop tremendous pulling forces and if used unsafely or improperly could result in property damage, serious injury or death. Throughout this manual you will find the following symbols for caution, warning and danger. Pay particular attention to the notes preceded by these symbols as they are written for your safety. Ultimately, safe operation of this device rests with you, the operator.



#### CAUTION

This indicates a potentially hazardous situation which, if not avoided, may result in minor or moderate injury. This notation is also used to alert you against unsafe practices.



#### WARNING

This indicates a potentially hazardous situation which, if not avoided, could result in death or serious injury.



# Safety warnings and precautions



## SAFETY WARNINGS AND PRECAUTIONS

**WARNING:** When using the tool, basic safety precautions should always be followed to reduce the risk of personal injury and damage to the equipment. Read all this instructions before using this tool!

**WARNING – Do not use winch to lift (vertically).**

**WARNING – Keep children away.** Children must never be allowed in the work area Do not let them handle machines, tools, or extension cords.

**WARNING – Store idle equipment.** When not in use, tools must be stored in a dry location to inhibit rust. Always lock up tools and keep out of reach of children.

**WARNING – Dress properly.** Do not wear loose clothing or jewelry as they can be caught in moving parts. Protective, electrically non-conductive clothes and non-skid footwear are recommended when working. Wear restrictive hair covering to contain long hair.

**WARNING – Use eye and ear protection.** Always wear impact safety goggles. Wear a full face shield if you are producing metal filings or wood chips. Wear a dust mask or respirator when working around metal, wood, and chemical dusts and mists.

**WARNING – Maintain tools with care.** Keep tools sharp and clean for better and safer performance. Follow instructions for lubricating and changing accessories. Inspect tool cords periodically and, if damaged, have them repaired by an authorized technician. The handles must be kept clean, dry, and free from oil and grease at all times.

**WARNING – Disconnect switch.** Unplug switch when not in use.

**WARNING – Stay alert.** Watch what you are doing, use common sense. Do not operate any tool when you are tired.

**WARNING – Check for damaged parts.** Before using any tool, any part that appears damaged should be carefully checked to determine that it will operate properly and perform its intended function. Check for alignment and binding of moving parts; any broken parts or mounting fixtures; and any other condition that may affect proper operation. Any part that is damaged should be properly repaired or replaced by a qualified technician. Do not use the tool if any switch does not turn “On” and “Off” properly.

**WARNING – Replacement parts and accessories.** When servicing, use only identical replacement parts. Use of any other parts will void the warranty. Only use accessories intended for use this tool.

**WARNING – Do not operate tool if under the influence of alcohol or drugs.** Read warning labels on prescription to determine if your judgment or reflexes are impaired while taking drugs. If there is any doubt, do not operate the tool.



**WARNING** – Keep hands and body away from Fairlead (cable intake slot) when operating.

**WARNING** –Secure vehicle in position before using winch.

**WARNING** –Be certain winch is properly bolted to a structure (or vehicle) that can hold the winch load.

**WARNING** – Do not use inappropriate attachments to extend the length of the winch cable.

**WARNING** – Never lift people or hoist loads over people.

**WARNING** – Never come in between the winch and the load when operating.

**WARNING** –Do not apply load to winch when cable is fully extended. Keep at least 5 full turns of cable on the spool.

**WARNING** – After moving an item with the winch, secure the item. Do not rely on the winch to hold it for an extended period.

**WARNING** – Examine winch before using. Components may be affected by exposure to chemicals, salts, and rust.

**WARNING** – Never operate winch if cable shows any signs of weakening, such as knotting or kinking.

**WARNING** – Do not cross over or under cable when the winch is under load.

**WARNING** – Do not move your vehicle with the cable extended and attached to the load. You could easily exceed the winch rating and snap the cable.

**WARNING** –Use gloves while handling cable.

**WARNING** – When the vehicle is parked on an incline you should use wheel chocks.

**WARNING** – Re-spool cable properly avoiding cable misalignment.

**WARNING** – The winch cable must be wound onto the drum under a load of at least 10% of the rated line pull or the outer wraps will draw into inner wraps and damage winch cable



**WARNING** – Before operating the winch under load you should check proper function of the winch by engaging and disengaging the clutch, by operating the directional controls, and operating the speed controls. This will ensure that the winch is working properly and will help prevent unintended damage and injury. Cycling the winch prior to loading will also ensure the gears are properly aligned.

## **UNPACKING**

When unpacking, check to make sure all parts are included. Refer to Assembly Drawings and Parts List (both with the like item numbers) at the end of this manual.

## **INSTALLATION**

1. Your 20000lb winch is designed with a bolt pattern that is standard in this class of winch. Many winch mounting kits are available that utilize this bolt pattern for the most popular vehicle and mounting channels. If you cannot find a kit locally, contact us and we will provide you with the name of a dealer near you. If you will utilize the mounting channel you must ensure that it is mounted on a flat surface so that the three major sections (motor, drum and gear housing) are properly aligned. Proper alignment of the winch will allow even distribution of the full rated load.
2. Start by connecting the roller fairlead to the mounting channel using 2 each of the cap screw, flat washer, lock washer and securing with nut. (Make sure the screw is placed through the mounting channel and roller fairlead from inside the channel. This will allow enough clearance for the winch to be placed in the channel without obstruction.)
3. Mount winch to the vehicle using high strength cap screw. It should be aligned and secured to a solid part of the vehicle (front or rear) where the the full rated load will be evenly distributed.
4. Connect the two-color (positive) battery cable from the directional valve to screw-down positive (+) terminal to the 12/24 volt battery.
5. Please refer to installation illustration.



### Mounting The Balance Valve:

The balance valve supplied is simply connected to motor. Be sure the balance valve's installing direction meets hydraulic principle chart. Otherwise, the winch will not reach the rated line pull, and it is also dangerous for winch to power off the cable with heavy load. If this symptom happens, simply disconnect the balance valve: exchange the oil hole between hydraulic motor and balance valve, while your winch is working in different direction, change  $A \rightarrow C1, B \rightarrow C2$  into  $A \rightarrow C2, B \rightarrow C1$ . And reconnect it. If your order demand the balance valve should be supplied, it will have been connected with the motor at the factory.

### Plumbing Connections:

Keep all hoses away from any areas where heat may be considered too extreme such as an exhaust manifold or turbo. Lines should not be allowed to rub on any abrasive or vibrating surfaces. In some applications, 90° fittings on the directional valve and motor or balance valve are necessary to make hose mounting more flexible. After plumbing has been laid out on vehicle, install o-ring fittings supplied to valve. Torque tight. Do not over tighten any fittings. Install o-ring fittings on Winch Motor. Torque tight. Connect any hose port A on motor or port V1 on balance valve to port A on directional valve, port B on motor or port V2 on balance valve to port B on directional valve, port P on directional valve to pump's high pressure port, port T on valve to reservoir, if necessary Connect any hose port S on valve to steering box. Attach any o-ring or seal from vehicles original tube fitting to tube fitting.

### Working hydraulic principle chart and installation illustration(U/A series):

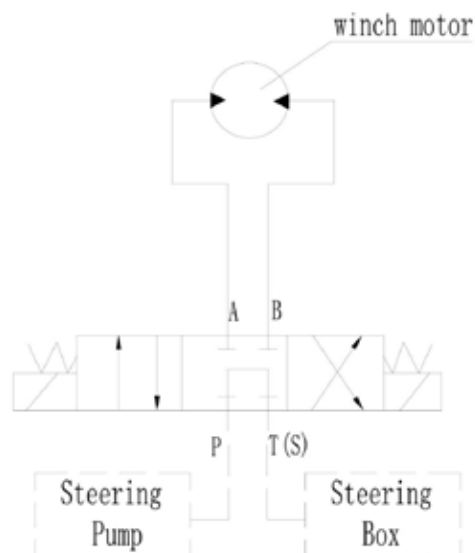





# Installation



## U Type

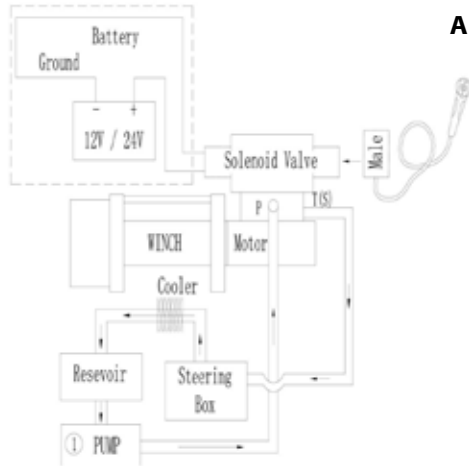

## A Type

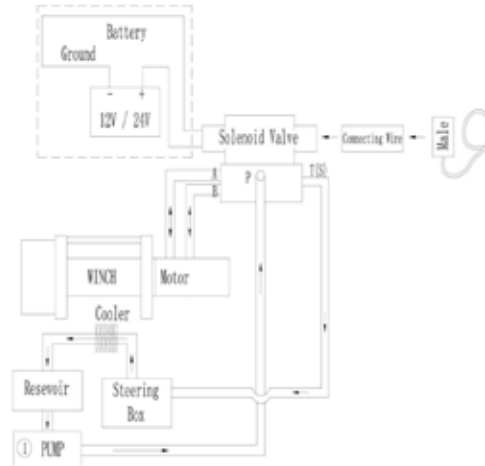

## The mounting drawing of U type

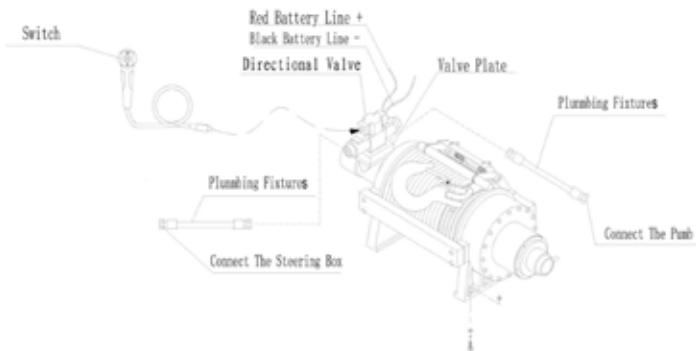

## The mounting drawing of A type

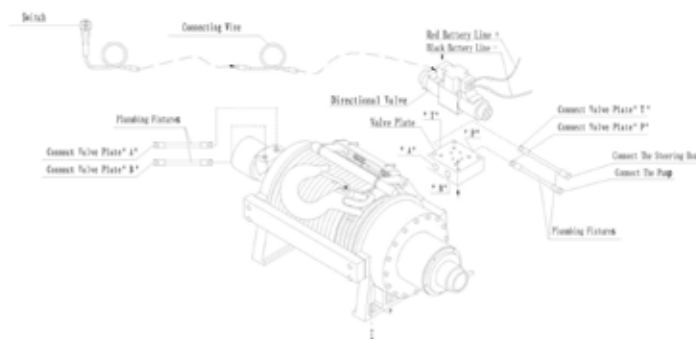



**Working hydraulic principle chart and installation illustration:**

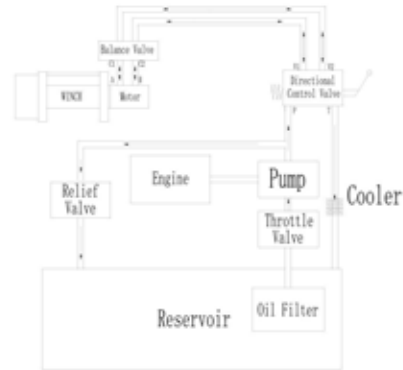
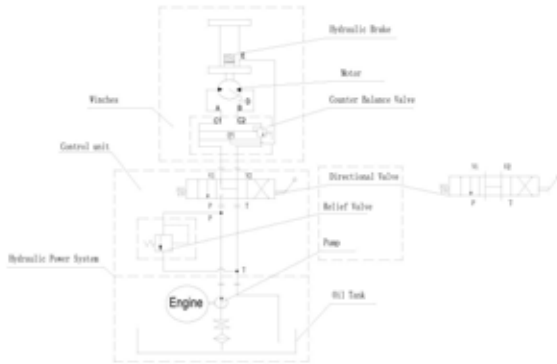

**Air actions clutch**

- Air clutch for Free spool

- Air clutch for free spool and two speed

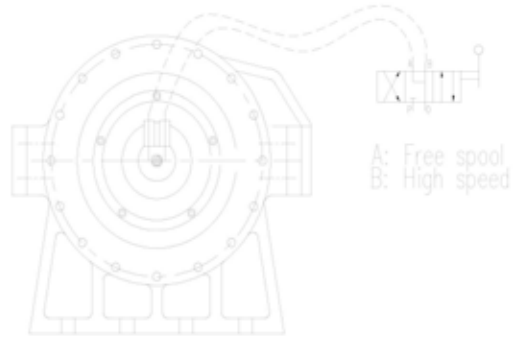
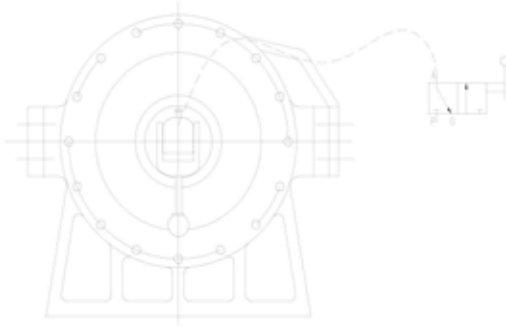

**PWY90sU/A/YP/YD-----Manual clutch operation of two speed**

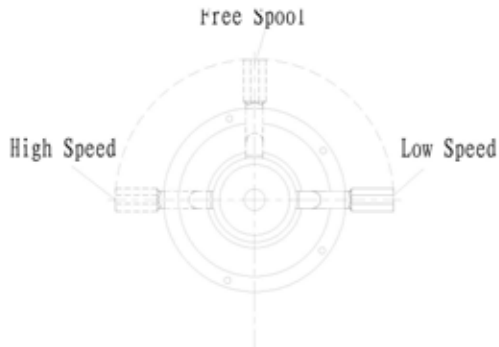



# Installation



## PWY90sU1/A1/Y1P/Y1D-----Air clutch operation of single speed

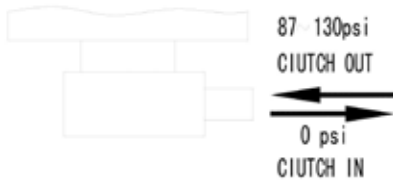

### WARNING

1. Clutch in all the time, when clutch out, need pressure 87~130psi into winch
2. Pressure should not below 87psi
3. When winch is loaded and working, Do not clutch out

## PWY90SU2U/A2Y2P /Y2D-----Air and manual mixed clutch operation of single speed

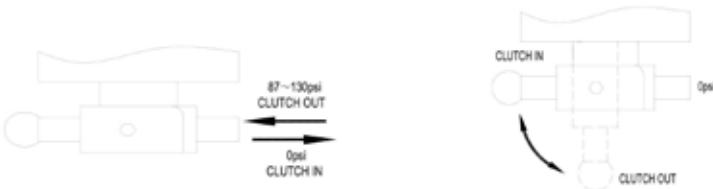

### WARNING

1. Pressure should not below 87psi.
2. When winch is loaded and working. Do not clutch out.
3. Clutch must be fully engaged before winching.

## PWY90sU3/A3/Y3P/Y3D-----Air clutch and air actions operation of two speed

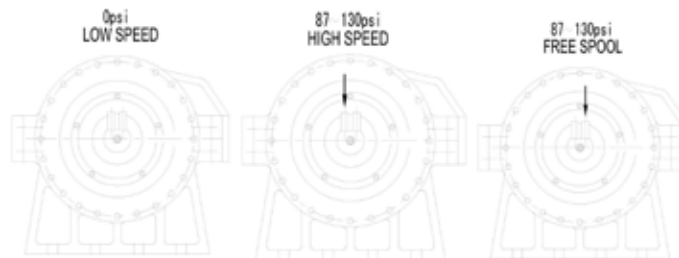



## WARNING

1. Pressure should not below 87psi.
2. When winch is loaded and working. Do not clutch out.
3. Clutch must be fully engaged before winching.

### Caution:

The hydraulic system needs a relief valve to ensure the system safety. The absence of such a valve could cause serious injury and damage the winch.

Winch battery cables should be placed so that there is a small amount of slack in the cable.

If you are using a heat exchanger with your application to cool the hydraulic fluid you should refer to the illustration about mounting.

You should check the hydraulic fluid level and replace any that may have seeped out. The hydraulic system should be purged at this time. Listed below are the directions on how to purge the hydraulic system.

- 1) Start the engine.
- 2) Power the winch to draw out about 5 feet of cable.
- 3) Shut down the engine.
- 4) Check the fluid level and fill as needed.
- 5) Repeat steps 1 through 4 as necessary.
- 6) Start the engine.
- 7) Move the cable into the desired position.
- 8) Turn the wheels on the vehicle from the right lock to the left lock positions five times to help bleed the hydraulic system.
- 9) If the hand control unit is working backwards, simple exchange the brown and the white wire connections within the valve.

Test the winch for proper operation. Refer to the section below.



## WARNING

1. Make sure clutch is totally engaged before starting any winch operation;
2. Stay clear and away from raised loads;
3. Stay clear of cable while pulling do not try to guide cable;
4. A min. of 5 wraps of cable around the drum barrel.

### General information:

The Winch's standard equipments contain gear reducer, drum, hydraulic motor, solenoid valve, switch assembly, female connector and plumbing fittings. The winch obtains its pressure from the vehicle's existing power steering pump or other hydraulic power. The winch is totally sealed, can be used underwater.

There are several other ways to supply power to the winch. The first way is to use an individual pump for engineering use. The second way is to provide the winch's hydraulic pressure is with the vehicle's exiting power steering pump (See Installation Instructions).

- Use a suitable individual pump, which doesn't have an oil pressure relief valve. It will supply pressure for both the steering box and the winch.

- Use a combined pump with an integrated oil valve. The oil valve will supply two kinds of flow based on the difference in demand. One type of flow will be constant and should be used with the steering system. The other will provide higher pressure and is for engineering use.

### Caution:

Hydraulic system needs an relief valve to make sure the system is safe; If there is not relief valve in the system; it would be serious danger and the system can't operation. If your winch driven by an existing hydraulic power system, the relief valve is also existing.



### **Winch working demonstration:**

1. Disengage the clutch by turning the clutch to the "Free Spool" position.
2. Grab the cable assembly and pull the cable to the desired length, then attach to item being pulled.  
Caution: Always leave at least five turns of cable on the drum; Review Winch Safety Warnings and Precautions on page 2, 3 before continuing.
3. Reengage the clutch by turning the clutch assembly to the "High Speed" or "Low Speed" position as needed.
4. Insert the switch assembly connector onto the directional valve
5. Test-run winch in both directions. Turn the winch in each direction for about one or two seconds meantime make the clutch totally engaged automatically.
6. While standing aside of the tow path, hold and operate the switch assembly supplied by your choice. Wait until the motor stops before reversing directions.
7. When the towing is finished, remove the switch assembly from the female connector of the directional valve and replace the female connector cover.



# Winch accessories you will need



## WINCH ACCESSORIES YOU WILL NEED

### NOT INCLUDED WITH YOUR WINCH

Gloves – For handling the wire rope and hook strap.

Anchor Strap/Chain – Tree saver anchor straps are made of high quality nylon with high tensile strengths up to 15000lbs.

Heavy Blanket – place on the cable to absorb energy should the wire rope break.

## RIGGING TECHNIQUES

### Self-Recovery

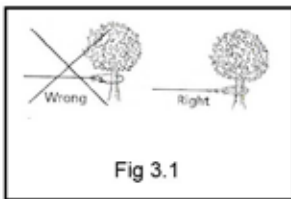

Locate a suitable anchor such as a strong tree trunk or boulder. Always use a sling as an anchor point. CAUTION Do not attach the clevis hook back onto the cable as this could cause damage to the cable. As shown in Fig 3.1

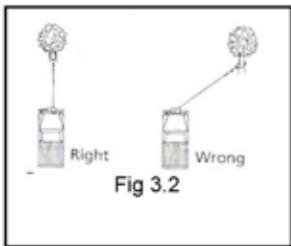

CAUTION Do not winch from an acute angle as the wire rope will pile up on one side of the drum causing damage to wire rope and the winch. Fig 3.2  
Short pulls from an angle can be used to straighten the vehicle. Long pulls should be done with the wire rope at a 90° angle to the winch/vehicle.

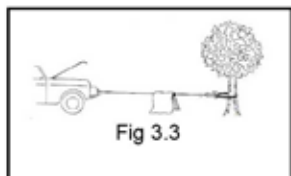

When pulling a heavy load, place a blanket or jacket over the wire rope five or six feet from the hook. In the event of a broken cable it will dampen the snap back. For additional protection open the hood of the vehicle as shown in Fig 3.3

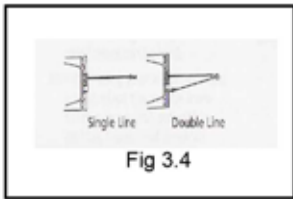

For pulls over 70% rated line pull, we recommend the use of the snatch block/pulley block to double line the wire rope. Fig 3.4

This reduces the load on the winch and the strain on the rope by up to 50% depending on the included angle.

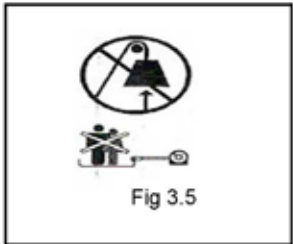

**WARNING** - Never use your winch for overhead hoisting or for lifting people or moving people.

## LUBRICATION

1. All moving parts within the Winch having been Lubricated using high temperature lithium grease at the factory. No internal lubrication is required.
2. Lubricate Cable Assembly periodically using a light penetrating oil.

## CABLE ASSEMBLY REPLACEMENT

If the wire rope has become worn or is beginning to show signs of strands breaking, it must be replaced before being used again.

1. Turning clutch to the "Free Spool" position.
2. Extend cable assembly to its full length. Note how the existing cable is connected to the drum.
3. Remove old cable assembly and attach new one as the old cable connected to the drum. Insert the end of the new rope and secure the screw being tightly screwed
4. Turning clutch to the "High Speed" position.
5. Retract cable assembly onto drum, first five wraps being careful not to allow kinking, then winch cable must be wound onto the drum under a load of at least 10% rated line pull.

**WARNING** - Only replace the wire rope with the identical replacement part recommended by the manufacturer.



## TROUBLE SHOOTING

SYMPTOM	POSSIBLE CAUSE	SUGGESTED ACTION
Winch does not turn .	-Insufficiently hydraulic system pressure. -Improper connections of hydraulic system, no oil into motor.	-Check relief valve regulate pressure. -Check all the plumbing fixtures according to the working principle chart. -Defective directional control valve.
Motor runs but Cable drum does not turn	- The clutch is Not engaged	-Turn the clutch to the high or lows peed position. If problem still persists, a qualified technician needed to check and repair.
Winch drum runs slowly or without normal power.	-Insufficient pressure or oil flow -Insufficient fluid in the system - Wrong winch working direction.	-Bump is not suitable or defective. Change a new one or a suitable one -Check fluid level. Add fluid until full. -Change the connection of balance valve and motor.
Winch brake not working normally.	-Hydraulic pressure remnants in brake while winch stop. -Wrong winch working direction.	-Use bigger back oil pipe.  -Change the connection of balance valve and motor.
Winch cannot spool off wire rope with load smoothly.	-Wrong winch working direction.	-Change the connection of balance valve and motor.



WINCH ASSEMBLY DRAWING PWY90s SERIES

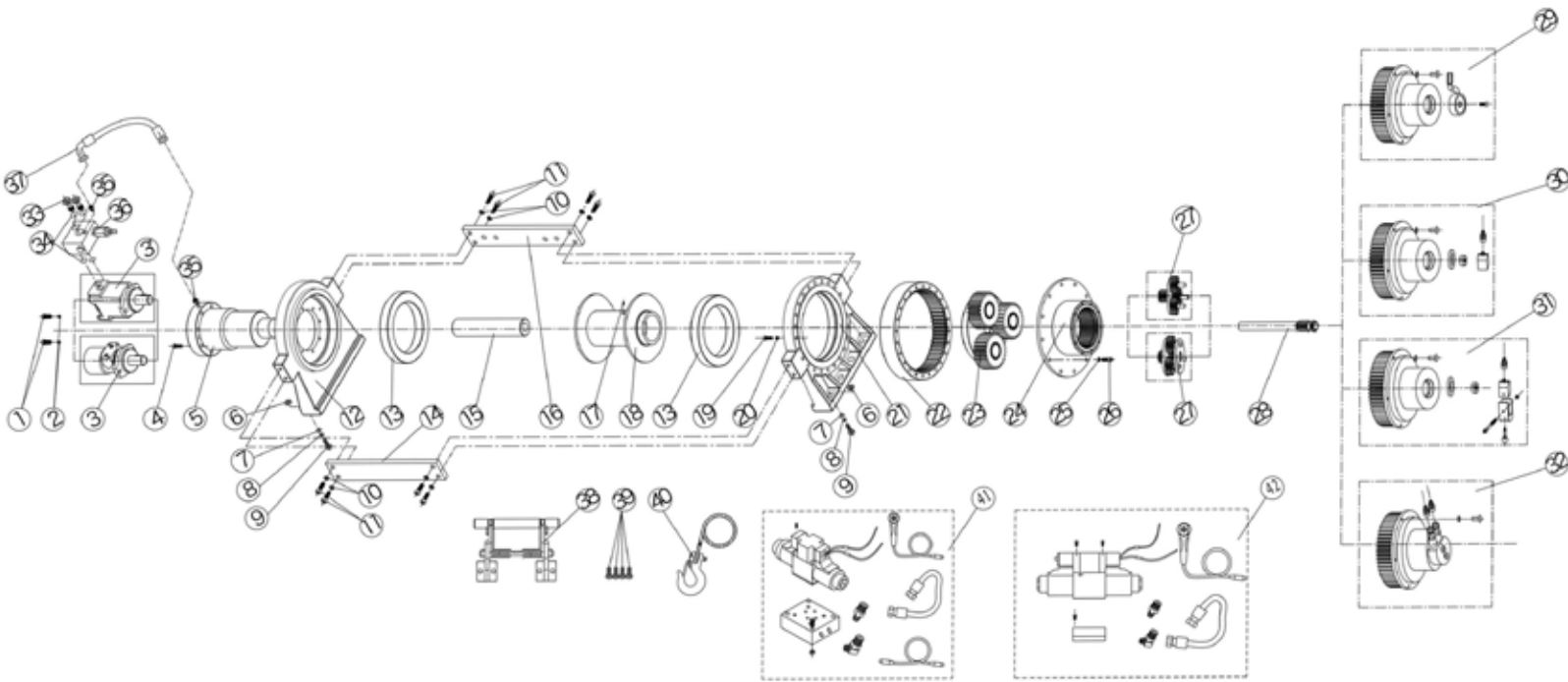

# Winch parts list PWY 90s Series



No.	Part #	Qty	Description	Remark
1	HP2000001	2	Screw M12 x 35	Used in YP series
		4		Used in YD series
2	HP2000002	2	Lock Washer Φ12	Used in YP series
		4		Used in YD series
3	HP2000100-1	1	Hydraulic Motor	Used in YP series
	HP2000100-2	1		Used in YD series
3'	HP2000100-3	1	Hydraulic Motor	Used in U/A series
4	HP2000003	8	Screw M8 x 30	Used in U/A/YP series
5	HP2000200	1	Break / Shaft Assembly	Used in U/A/YP series
6	HP2000004	8	Hex Flange Nut M14	
7	HP2000005	8	Think Flat Washer Φ14	
8	HP2000006	8	Lock Washer Φ14	
9	HP2000007	8	Cap Screw M14 x 50	
10	HP2000008	4	Lock Washer Φ10	
11	HP2000009	4	Screw M10 x 30	
12	HP2000010	1	Front Bearing	
13	HP2000011	2	Roller Bearing	
14	HP2000012-1	1	Frontal Mounting Plata	Used in YP/YD series
	HP2000012-2	1	Frontal Mounting Plata	Used in U/A series
15	HP2000013-1	1	Coupling	Used in YP/YD series
	HP2000013-2	1	Coupling	Used in U/A series
16	HP2000014-1	1	Back Mounting Plata	Used in YP/YD series
	HP2000014-2	1	Back Mounting Plata	Used in U/A series
17	HP2000015	1	Screw M8 x 10	
18	HP2000300-1	1	Drum Assembly	Used in YP/YD series
	HP2000300-2	1	Drum Assembly	Used in U/A series
19	HP2000016	24	Screw M8 x 35	
20	HP2000017	24	Lock Washer Φ8	
21	HP2000018	1	End Bearing	
22	HP2000019	1	Gear-Ring	
23	HP2000400	1	Gear Carrier Assembly (Output)	
24	HP2000500	1	Cam Gear (Input)	
25	HP2000017	12	Lock Washer Φ8	
26	HP2000020	12	Screw M8 x 20	
27	HP2000600-1	1	Gear Carrier Assembly (Input)	Used in Y1P/Y2P /U1/U2/A/1A2
27'	HP2000600-2	1	Gear Carrier Assembly (Input)	Used in YP/Y3P/YD /U/U3/A/A3
28	HP2000021	1	Transmission Shaft	
29	HP2000700	1	Clutch Assembly	Used in YP/YD/U/A
30	HP2000800	1	Clutch Assembly	Used in Y1P/U1/A1
31	HP2000900	1	Clutch Assembly	Used in Y2P/U2/A2
32	HP2001000	1	Clutch Assembly	Used in Y3P/U3/A3
33	HP2000032	2	Screw	Used in YP series
34	HP2000033	4	Seal Ring	Used in YP series
35	HP2001100	2	Tube Fittings Assembly	Used in YP series
36	HP2001200	1	Balanced Valve Assembly	Used in YP series
37	HP2001300	1	Plumbing Fixtures	Used in YP series
38	HP2001400	1	Tensioned Of Steel Wire Supplied Assembly	
39	HP2000031	4	Screw M10 x 25	
40	HP2001500	1	Cable Assembly	
41	HP2001600	1	Control Section	Used in U series
42	HP2001700	1	Control Section	Used in A series



WINCH ASSEMBLY DRAWING PWY90xs SERIES

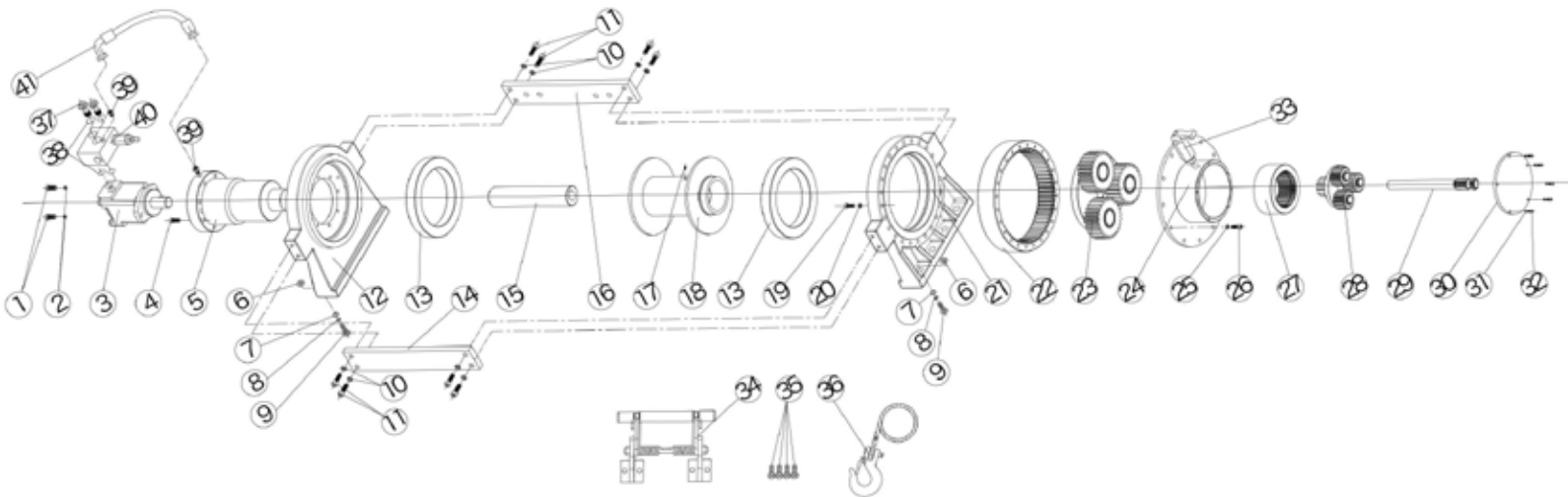

# Winch parts list PWY90xs Series



No.	Part #	Qty	Description	Remark
1	HX2000001	2	Screw M12 x 35	Used in YP series
		4		Used in YD series
2	HX2000002	2	Lock Washer Φ12	Used in YP series
		4		Used in YD series
3	HX2000100-1	1	Hydraulic Motor	Used in YP series
	HX2000100-2	1		Used in YD series
4	HX2000003	8	Screw M8 x 30	
5	HX2000200	1	Break / Shaft Assembly	Used in YP series
6	HX2000004	8	Hex Flange Nut M14	
7	HX2000005	8	Thin Flat Washer Φ14	
8	HX2000006	8	Lock Washer Φ14	
9	HX2000007	8	Cap Screw M14 x 50	
10	HX2000008	4	Lock Washer Φ10	
11	HX2000009	4	Screw M10 x 30	
12	HX2000010	1	Front Bearing	
13	HX2000011	2	Roller Bearing	
14	HX2000012-1	1	Frontal Mounting Plata	Used in YP series
	HX2000012-2	1	Frontal Mounting Plata	Used in YD series
15	HX2000013-1	1	Coupling	Used in YP series
	HX2000013-2	1	Coupling	Used in YD series
16	HX2000014-1	1	Back Mounting Plata	Used in YP series
	HX2000014-2	1	Back Mounting Plata	Used in YD series
17	HX2000015	1	Screw M8 x 10	
18	HX2000300-1	1	Drum Assembly	Used in YP series
	HX2000300-2	1	Drum Assembly	Used in YD series
19	HX2000016	24	Screw M8 x 35	
20	HX2000017	24	Lock Washer Φ8	
21	HX2000018	1	End Bearing	
22	HX2000019	1	Gear-Ring	
23	HX2000400	1	Gear Carrier Assembly (Output)	
24	HX2000500	1	Cam Gear (Input)	
25	HX2000017	12	Lock Washer Φ8	
26	HX2000020	12	Screw M8 x 20	
27	HX2000021	1	Gear-Ring	
28	HX2000600	1	Gear Carrier Assembly (Input)	
29	HX2000022	1	Transmission Shaft	
30	HX2000023	1	Cover-Gear Housing	
31	HX2000024	5	Lock Washer Φ4	
32	HX2000025	5	Screw M4 x 15	
33	HX2000700	1	Clutch Assembly	
34	HX2000800	1	Tensioned Of Steel Wire Supplied Assembly	
35	HX2000026	4	Screw M10 x 25	
36	HX2000900	1	Cable Assembly	Used in YP series
37	HX2000027	2	Screw	Used in YP series
38	HX2000028	4	Seal Ring	Used in YP series
39	HX2001000	2	Tube Fittings Assembly	Used in YP series
40	HX2001100	1	Balanced Valve Assembly	Used in YP series
41	HX2001200	1	Plumbing Fixtures	Used in YP series



**PWY90sU**

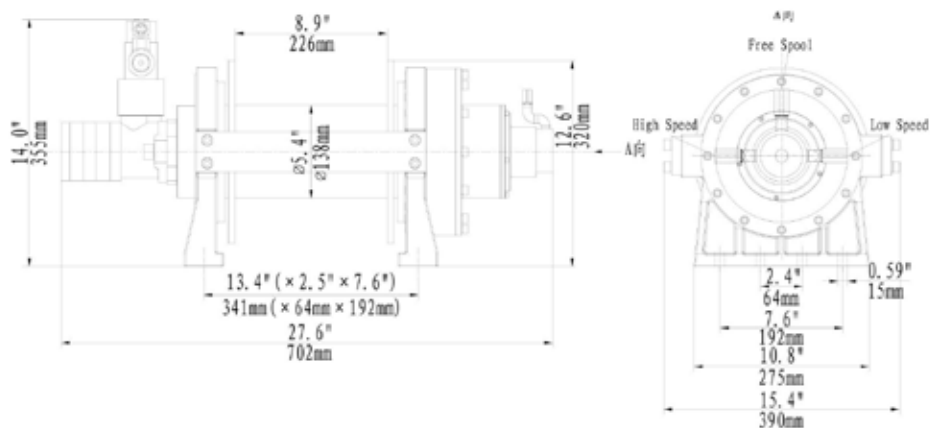

**PWY90sA**

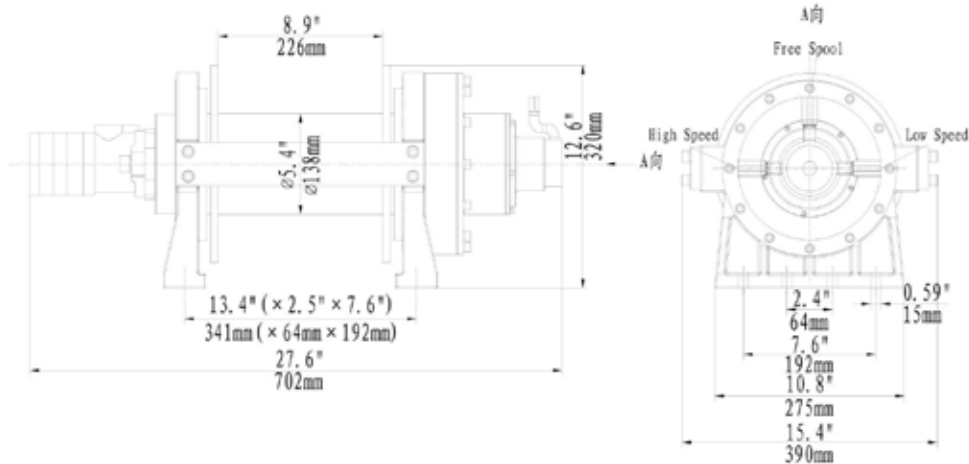

**PWY90sYP**

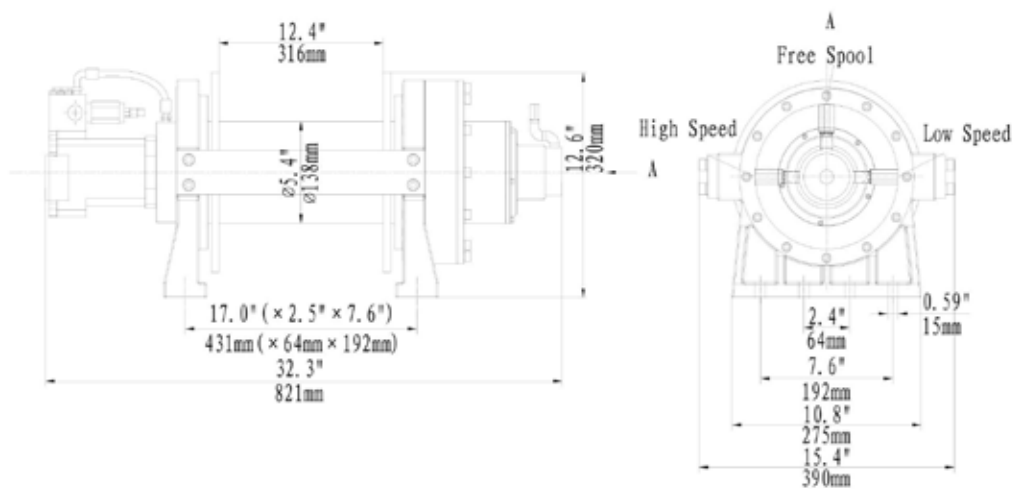



# Outline dimensional drawing



**PWY90sYD**

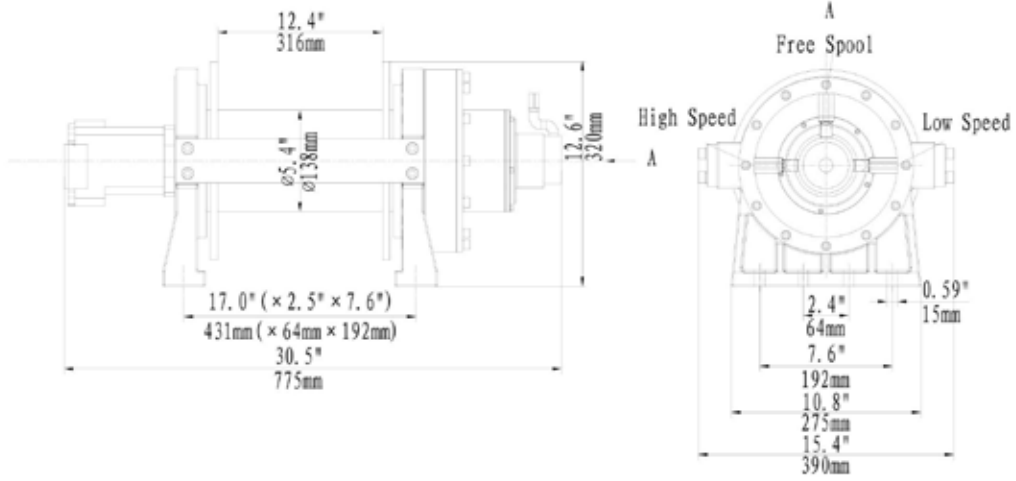

**PWY90xsYP**

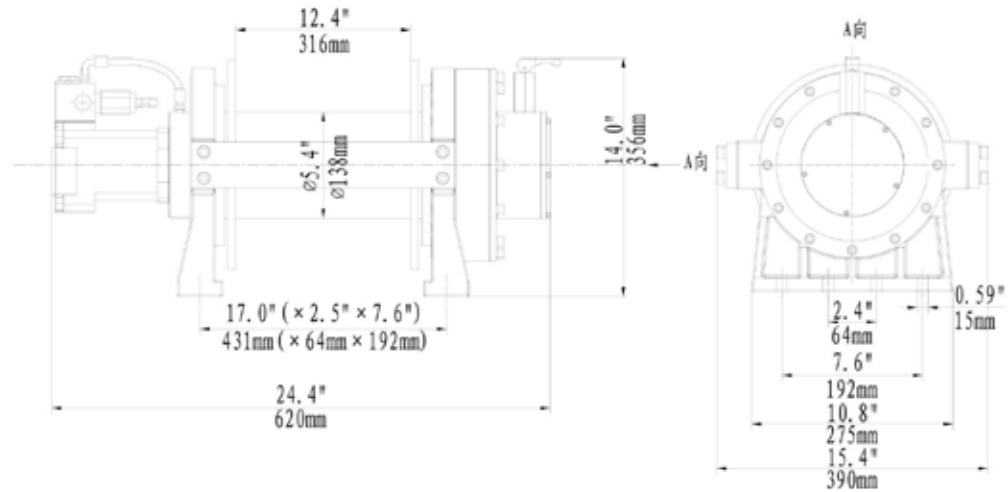

**PWY90xsYD**

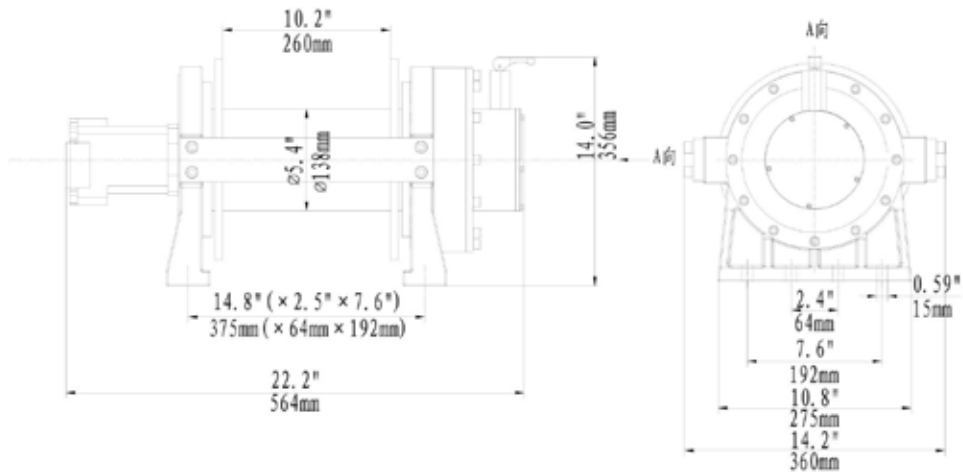

# Specification (PWY90sU/A U3/A3)



Rated line pull	20000lbs (9072 kgs)	
Motor displacement	125ml/r	
Oil flow	5~45L/min	
Pressure	14.5Mpa	
Gear reduction ratio	High speed: 6:1;Low speed: 39:1	
Cable (Dia. × L)	Ø9/16" × 105 ' (Ø14mm × 32m)	
Drum size(Dia. × L)	Ø5.43 " × 8. 9" (Ø138mm × 226mm)	
Mounting bolt pattern	13.4" × 2.5 " × 7.6" (341mm × 64mm × 192mm) 8-M14	
Item	PWY90SU	PWY90SA
Overall dimensions (L × W × H)	27.6" × 15.4" × 14.0" 702mm × 390mm × 355mm	27.6" × 15.4" × 12.6" 702mm × 390mm × 320mm
Net weight lbs(kg)	320 145	315 143
Item	PWY90SU3	PWY90SA3
Overall dimensions (L × W × H)	28.2" × 15.4" × 14.0" 717mm × 390mm × 355mm	28.2" × 15.4" × 12.6" 717mm × 390mm × 320mm
Net weight lbs(kgs)	320 145	315 143

### Pull , Speed, Pressure, Flow (First layer)

Line pull lbs (kgs)		Pressure Mpa(Psi)	Flow G/min (L/min)	Line speed ft/min(m/min)	
Low speed	High speed			Low speed	High speed
0	0	2.0(362.6)	1.3(5)	1.3(0.4)	1.6(0.5)
4000(1814)	696(316)	3.3(478.6)	2.6(10)	3.3(1.0)	11.5(3.5)
8000(3629)	1391(631)	6.8(986.2)	5.3(20)	6.2(1.9)	29.5(9.0)
15000(6804)	2609(1183)	11.0(1595.4)	9.2(35)	10.8(3.3)	56.1(17.1)
20000(9072)	3478(1578)	14.5(2103.0)	11.9(45)	14.1(4.3)	74.8(22.8)

### Line pull, cable capacity and the line speed per layer

Layer of wire rope	Rated line pull lbs(kgs)	Total rope on drum ft (m)	While oil flow 35L/min	
			Low speed ft/min(m/min)	High speed ft/min(m/min)
1	20000(9072)	23.6(7.2)	10.8(3.3)	62.7(19.1)
2	16889(7661)	51.8(15.8)	12.8(3.9)	74.2(22.6)
3	14615(6629)	82.0(25.0)	14.8(4.5)	85.6(26.1)
4	12881(5843)	105.0(32.0)	17.1(5.2)	98.4(30.0)





# Specification (PWY90sU1/A1 U2/A2)



Rated line pull	20000 lbs (9072 kgs)	
Motor displacement	125ml/r	
Oil flow	5~45L/min	
Pressure	14.5Mpa	
Gear reduction ratio	39:1	
Cable (Dia.× L)	Ø9/16"×105 ' (Ø14mm×32m)	
Drum size(Dia.× L)	Ø5.43 "×8. 9" (Ø138mm×226mm)	
Mounting bolt pattern	13.4"×2.5 "×7.6" (341mm×64mm×192mm) 8-M14	
Item	PWY90SU1	PWY90SA1
Overall dimensions (L×W×H)	28.2"×15.4"×14.0" 717mm ×390mm ×355mm	28.2"×15.4"×12.6" 717mm ×390mm ×320mm
Net weight lbs(kg)	320 145	315 143
Item	PWY90SU2	PWY90SA2
Overall dimensions (L×W×H)	32.4"×15.4"×14.0" 822mm ×390mm ×355mm	32.4"×15.4"×12.6" 822mm ×390mm ×320mm
Net weight lbs(kgs)	320 145	315 143

### Pull , Speed, Pressure, Flow (First layer)

Line pull lbs (kgs)	Pressure Mpa(Psi)	Flow G/min (L/min)	Line speed ft/min(m/min)
0	2.0(362.6)	1.3(5)	1.3(0.4)
4000(1814)	3.3(478.6)	2.6(10)	3.3(1.0)
8000(3629)	6.8(986.2)	5.3(20)	6.2(1.9)
15000(6804)	11.0(1595.4)	9.2(35)	10.8(3.3)
20000(9072)	14.5(2103.0)	11.9(45)	14.1(4.3)

### Line pull, cable capacity and the line speed per layer

Layer of wire rope	Rated line pull lbs(kgs)	Total rope on drum ft (m)
1	20000(9072)	23.6(7.2)
2	16889(7661)	51.8(15.8)
3	14615(6629)	82.0(25.0)
4	12881(5843)	105.0(32.0)



Rated line pull	20000 lbs (9072 kgs)	
Motor displacement	100ml/r	
Oil flow	15~75L/min	
Pressure	17.5Mpa	
Gear reduction ratio	High speed: 6:1;Low speed: 39:1	
Cable (Dia. × L)	Ø9/16" × 157 ' (Ø14mm × 48m)	
Drum size(Dia. × L)	Ø5.4 " × 12.4" (Ø138mm × 316mm)	
Mounting bolt pattern	17.0 " × 2.5 " × 7.6 " (431mm × 64mm × 192mm) 8-M14	
Item	PWY90SYP	PWY90SY3P
Overall dimensions (L × W × H)	32.3" × 15.4" × 12.6" 821mm × 390mm × 320mm	32.7" × 15.4" × 12.6" 830mm × 390mm × 320mm
Net weight lbs(kg)	360 163	360 163

### Pull , Speed, Pressure, Flow (First layer)

Line pull lbs (kgs)		Pressure Mpa(Psi)	Flow G/min (L/min)	Line speed ft/min(m/min)	
Low speed	High speed			Low speed	High speed
0	0	2.5(362.6)	4.0(15)	5.9(1.8)	27.2(8.3)
4000(1814)	696(316)	4.2(609.1)	7.9(30)	11.8(3.6)	60.7(18.5)
8000(3629)	1391(631)	8.5(1232.8)	13.2(50)	19.7(6.0)	106.0(32.3)
15000(6804)	2609(1183)	14.0(2030.5)	15.9(60)	23.6(7.2)	129.3(39.4)
20000(9072)	3478(1578)	17.5(2538.1)	19.9(75)	29.5(9.0)	164.0(50.0)

### Line pull, cable capacity and the line speed per layer

Layer of wire rope	Rated line pull lbs(kgs)	Total rope on drum ft (m)	While oil flow 60L/min	
			Low speed ft/min(m/min)	High speed ft/min(m/min)
1	20000(9072)	33.8(10.3)	23.6(7.2)	135.8(41.4)
2	16889(7661)	73.8(22.5)	27.9(8.5)	160.8(49.0)
3	14615(6630)	117.8(35.9)	32.2(9.8)	185.7(56.6)
4	12881(5843)	157.5(48.0)	36.7(11.2)	204.1(62.2)

# Specification (PWY90sY1P/Y2P)



Rated line pull	20000 lbs (9072 kgs)	
Motor displacement	100ml/r	
Oil flow	15~75L/min	
Pressure	17.5Mpa	
Gear reduction ratio	39:1	
Cable (Dia. × L)	Ø9/16" × 157' (Ø14mm × 48m)	
Drum size (Dia. × L)	Ø5.4" × 12.4" (Ø138mm × 316mm)	
Mounting bolt pattern	17.0" × 2.5" × 7.6" (431mm × 64mm × 192mm) 8-M14	
Item	PWY90SY1P	PWY90SY2P
Overall dimensions (L × W × H)	32.7" × 15.4" × 12.6" 830mm × 390mm × 320mm	36.8" × 15.4" × 12.6" 935mm × 390mm × 320mm
Net weight lbs(kg)	360 163	360 163

## Pull, Speed, Pressure, Flow (First layer)

Line pull lbs (kgs)	Pressure Mpa(Psi)	Flow G/min (L/min)	Line speed ft/min(m/min)
0	2.5(362.6)	4.0(15)	5.9(1.8)
4000(1814)	4.2(609.1)	7.9(30)	11.8(3.6)
8000(3629)	8.5(1232.8)	13.2(50)	19.7(6.0)
15000(6804)	14.0(2030.5)	15.9(60)	23.6(7.2)
20000(9072)	17.5(2538.1)	19.9(75)	29.5(9.0)

## Line pull, cable capacity and the line speed per layer

Layer of wire rope	Rated line pull lbs(kgs)	Total rope on drum ft (m)
1	20000(9072)	33.8(10.3)
2	16889(7661)	73.8(22.5)
3	14615(6630)	117.8(35.9)
4	12881(5843)	157.5(48.0)



Rated line pull	20000 lbs (9072 kgs)	
Motor displacement	100ml/r	
Oil flow	15~75L/min	
Pressure	17.5Mpa	
Gear reduction ratio	High speed: 6:1;Low speed: 39:1	
Cable (Dia. × L)	Ø9/16" × 157 ' (Ø14mm × 48m)	
Drum size(Dia. × L)	Ø5.4 " × 12.4" (Ø138mm × 316mm)	
Mounting bolt pattern	17.0 " × 2.5 " × 7.6 " (431mm × 64mm × 192mm) 8-M14	
Item	PWY90SYD	PWY90SY3D
Overall dimensions (L × W × H)	30.5" × 15.4" × 12.6" 775mm × 390mm × 320mm	30.9" × 15.4" × 12.6" 781mm × 390mm × 320mm
Net weight lbs(kgs)	360 163	360 163

### Pull , Speed, Pressure, Flow (First layer)

Line pull lbs (kgs)		Pressure Mpa(Psi)	Flow G/min (L/min)	Line speed ft/min(m/min)	
Low speed	High speed			Low speed	High speed
0	0	2.5(362.6)	4.0(15)	5.9(1.8)	27.2(8.3)
4000(1814)	696(316)	4.2(609.1)	7.9(30)	11.8(3.6)	60.7(18.5)
8000(3629)	1391(631)	8.5(1232.8)	13.2(50)	19.7(6.0)	106.0(32.3)
15000(6804)	2609(1183)	14.0(2030.5)	15.9(60)	23.6(7.2)	129.3(39.4)
20000(9072)	3478(1578)	17.5(2538.1)	19.9(75)	29.5(9.0)	164.0(50.0)

### Line pull, cable capacity and the line speed per layer

Layer of wire rope	Rated line pull lbs(kgs)	Total rope on drum ft (m)	While oil flow 60L/min	
			Low speed ft/min(m/min)	High speed ft/min(m/min)
1	20000(9072)	33.8(10.3)	23.6(7.2)	135.8(41.4)
2	16889(7661)	73.8(22.5)	27.9(8.5)	160.8(49.0)
3	14615(6629)	117.8(35.9)	32.2(9.8)	185.7(56.6)
4	12881(5843)	157.5(48.0)	36.7(11.2)	204.1(62.2)

# Specification (PWY90sY1D/Y2D)



Rated line pull	20000 lbs (9072 kgs)	
Motor displacement	100ml/r	
Oil flow	15~75L/min	
Pressure	17.5Mpa	
Gear reduction ratio	39:1	
Cable (Dia. × L)	Ø9/16" × 157 ' (Ø14mm × 48m)	
Drum size(Dia. × L)	Ø5.4 " × 12.4" (Ø138mm × 316mm)	
Mounting bolt pattern	17.0 " × 2.5 " × 7.6 " (431mm × 64mm × 192mm) 8-M14	
Item	PWY90SY1D	PWY90SY2D
Overall dimensions (L × W × H)	30.9" × 15.4" × 12.6" 784mm × 390mm × 320mm	35.0" × 15.4" × 12.6" 889mm × 390mm × 320mm
Net weight lbs(kgs)	360 163	360 163

## Pull , Speed, Pressure, Flow (First layer)

Line pull lbs (kgs)	Pressure Mpa(Psi)	Flow G/min (L/min)	Line speed ft/min(m/min)
0	2.5(362.6)	4.0(15)	5.9(1.8)
4000(1814)	4.2(609.1)	7.9(30)	11.8(3.6)
8000(3629)	8.5(1232.8)	13.2(50)	19.7(6.0)
15000(6804)	14.0(2030.5)	15.9(60)	23.6(7.2)
20000(9072)	17.5(2538.1)	19.9(75)	29.5(9.0)

## Line pull, cable capacity and the line speed per layer

Layer of wire rope	Rated line pull lbs(kgs)	Total rope on drum ft (m)
1	20000(9072)	33.8(10.3)
2	16889(7661)	73.8(22.5)
3	14615(6629)	117.8(35.9)
4	12881(5843)	157.5(48.0)



Rated line pull	20000 lbs (9072 kgs)
Motor displacement	100ml/r
Oil flow	15~75L/min
Pressure	17.5Mpa
Gear reduction ratio	39:1
Cable (Dia. × L)	Ø9/16" × 157 ' (Ø14mm × 48m)
Drum size (Dia. × L)	Ø5.4 " × 12.4" (Ø138mm × 316mm)
Mounting bolt pattern	17.0 " × 2.5 " × 7.6 " (431mm × 64mm × 192mm) 8-M14
Overall dimensions (L × W × H)	24.4" × 15.4" × 14.0" 620mm × 390mm × 356mm
Net weight lbs(kgs)	238 108

### Pull , Speed, Pressure, Flow (First layer)

Line pull lbs (kgs)	Pressure Mpa(Psi)	Flow G/min (L/min)	Line speed ft/min(m/min)
0	2.5(362.6)	4.0(15)	5.9(1.8)
4000(1814)	4.2(609.1)	7.9(30)	11.8(3.6)
8000(3629)	8.5(1232.8)	13.2(50)	19.7(6.0)
15000(6804)	14.0(2030.5)	15.9(60)	23.6(7.2)
20000(9072)	17.5(2538.1)	19.9(75)	29.5(9.0)

### Line pull, cable capacity and the line speed per layer

Layer of wire rope	Rated line pull lbs(kgs)	Total rope on drum ft (m)
1	20000(9072)	33.8(10.3)
2	16889(7661)	73.8(22.5)
3	14615(6629)	117.8(35.9)
4	12881(5843)	157.5(48.0)



# Specification (PWY90xsYD)



Rated line pull	20000 lbs (9072 <u>kgs</u> )
Motor displacement	100ml/r
Oil flow	15~75L/min
Pressure	17.5Mpa
Gear reduction ratio	39:1
Drum <u>size</u> (Dia. × L)	Ø5.4 "×10.2" (Ø138mm×260mm)
Mounting bolt pattern	14.8 "×2.5 " ×7.6 " (375mm×64mm×192mm) 8-M14
Overall dimensions (L×W×H)	22.2"×14.2"×14.0" 564mm ×360mm ×356mm
Net weight <u>lbs(kgs)</u>	238 108

### Pull , Speed, Pressure, Flow (First layer)

Line pull <u>lbs (kgs)</u>	Pressure <u>Mpa(Psi)</u>	Flow G/min (L/min)	Line speed <u>ft/min(m/min)</u>
0	2.5(362.6)	4.0(15)	5.9(1.8)
4000(1814)	4.2(609.1)	7.9(30)	11.8(3.6)
8000(3629)	8.5(1232.8)	13.2(50)	19.7(6.0)
15000(6804)	14.0(2030.5)	15.9(60)	23.6(7.2)
20000(9072)	17.5(2538.1)	19.9(75)	29.5(9.0)



## LIMITED WARRANTY COVERAGE

PROWINCH products are warranted to the original purchaser for a period of three (3) years after the date of purchase only to be free from defects in material and workmanship when subjected to normal, proper and intended use. Within this period, PROWINCH will only repair or replace free of charge any part on a product, after examination, is determined by PROWINCH to be defective in material or workmanship and was not caused or substantially contributed to by other factors or circumstances beyond PROWINCH control, including (but not limited to) defective installation, maintenance or repair, product modification or alteration, any neglect misuse or excessive use, mishandling, product exposure to extreme or unsuitable conditions, normal wear and tear or failure to follow manufacturer's instructions. This warranty does not apply to damage that PROWINCH determines to be from repairs made or attempted by anyone other than PROWINCH authorized personnel.

Return of the product with a copy of proof of purchase to PROWINCH, freight prepaid and insured, are required for this warranty to be effective. If more than one year has elapsed from purchase date, proof of periodic and regular maintenance by an authorized service must also be provided for this warranty to be effective. PROWINCH does not cover freight or labor charges associated with the inspection and testing of products which are found by PROWINCH not to be a valid warranty claim.

## DISCLAIMER

In no event shall PROWINCH be liable for any labor, removal and installation expenses, loss of time, manufacturing costs, transportation, materials, loss of profits, incidental, special, consequential or punitive damages, or for any costs, attorney fees, expenses, losses or delays, direct or indirect, alleged to be as a consequence of any damage to, failure of, or defect in any product including, but not limited to, any claims for loss of profits. PROWINCH disclaims any implied warranties, including without limitation, any implied warranty of merchantability or fitness for a particular use or purpose.

Acceptance of the exclusive repair and replacement remedies described herein is a condition of the contract for the purchase of every PROWINCH product. If you do not agree to this condition, you should not purchase the product.





**Pro** **///** **INCH**

