

# ProWINCH<sup>®</sup>

Reg. U.S. TM. Off.

**PWA**  
**PWX**

**User's Manual / Manual de usuario**  
**Safety Warnings / Advertencias de seguridad**

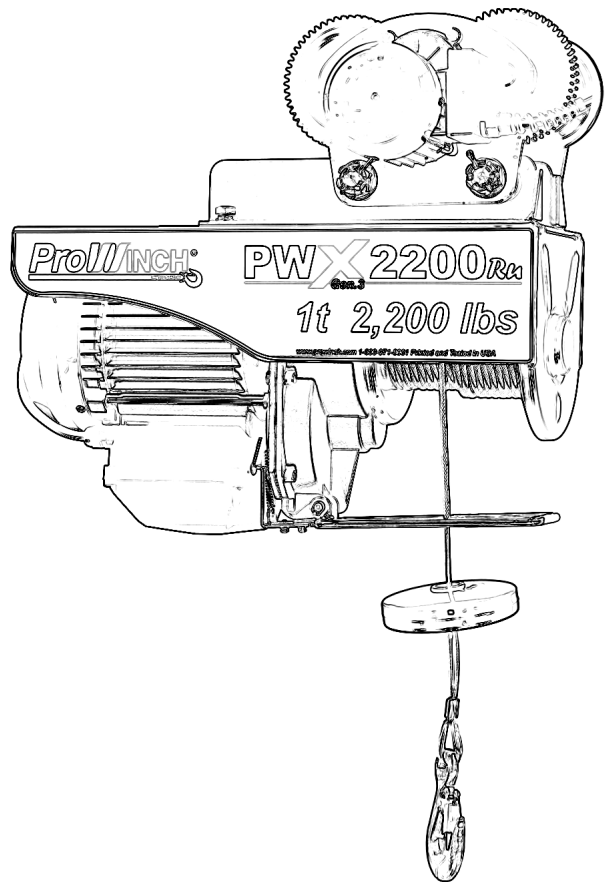

**This page intentionally left blank**

PROPERTY REGISTRY N° 189487  
ANY REPRODUCTION IS FORBIDDEN  
PROPERTY OF PROWINCH® 2018 - V8.0 ALL RIGHTS RESERVED  
PROWINCH LLC COMPANY WITH QUALITY MANAGEMENT SYSTEM

## PROWINCH® DISCLAIMER

---

Prowinch® LLC declares that it has made available to the Customer each and every one of the security warnings related to the purchased product and that, as a result, it does not assume any responsibility for any damages or losses that may be suffered by the client or third parties, cause or as a direct or indirect consequence of the breach or omission of any of the instructions or safety warnings contained in the User Manual and Security Warnings corresponding to the unit purchased.

In this sense, Prowinch® LLC will not be liable for accidents and / or damages to persons and / or property resulting from the negligent use of the product.

In no case does Prowinch® LLC assume any liability arising from the use of these voluntary recommendations, and does not offer any guarantee in relation to them. These recommendations do not take precedence over the current safety regulations of the plant.

For purposes of enforcing the Warranty of the product purchased, Prowinch® LLC, will only be liable for any damage when it is possible to prove that the user has followed each and every one of the warnings contained in the User Manual and Safety Warnings.

1. It is the sole responsibility of the Client / User to verify that the acquired equipment, products and accessories comply with the characteristics, capacities, elements, components, accessories and other conditions for the use that the Client / user intends to give it.
2. It is also the sole responsibility of the Client / User to ensure that the equipment and products purchased are operated and maintained in safety conditions and by personnel duly trained in the use thereof, also implementing all the security measures necessary for prevent accidents or damages to people or property and observing the indications and warnings of the corresponding manuals of use.
3. The possible support in the selection of the equipment, the capacities and characteristics required by the clients that Prowinch provides is delivered free of charge and provided based on the information of use and requirements indicated by the Client itself, information that Prowinch does not It may not correspond to verify. In this way, it is in any case the sole and exclusive responsibility of the Client -or who will use the equipment and products acquired- to ensure that they comply with the capabilities, characteristics, up-to-date maintenance and everything necessary for a correct and safe operation in relation to the intended use.
4. For personnel lifting Prowinch recommends the use of winches with 4 brakes. The use of winches of 3 or less brakes or safety features lower than the maximum available, for personnel lifting, is the sole responsibility of the customer.
5. In order to guarantee the safety of the users of the equipment, especially those of Personnel, it is necessary to carry out the inspections and maintenance of the equipment according to the recommended frequency in relation to its work cycle, as it is described by the ASME B30 standards. It is mandatory to keep record and evidence the written and photographic reports of: Maintenance, Start-up, Load Tests, Training, Certifications, Inspections and Reports of failures and accidents.
6. The aforementioned reports must be sent by email to [registros@prowinch.com](mailto:registros@prowinch.com) within the first 7 calendar days that said event has occurred.
7. Compliance with the timely implementation of the mandatory activities described in points 6 and 7, plus all the activities mentioned in the corresponding rules applied, are the sole responsibility of the user. Failure to comply with the foregoing, releases Prowinch from any type of Liability and Warranty to the team, customer, staff and / or user or any other liability that could be attributed to Prowinch.

The information contained in this manual may contain technical errors or inaccuracies, Prowinch® LLC, is not responsible for errors typing, omission or incorrect information.

This manual is subject to change without prior notice. Download the latest version available at [www.prowinch.com](http://www.prowinch.com)  
Always check [www.prowinch.com](http://www.prowinch.com) for latest information regarding this product.

Disclaimer .....	3
Safety Precautions .....	6
Hoist Safety Precautions .....	7
Before Using the equipment .....	7
During Operation .....	8
Inspection, Maintenance and repairs .....	8
Specifications .....	15
Product Code .....	15
Specification Chart .....	15
Load Level and Service Life .....	16
Electric wire rope hoist Specifications .....	18
Oil & Lubricant Recommendations .....	19
Installation .....	20
Installation .....	20
Unpacking .....	20
Electrical Connections .....	21
Install Trolley (models with trolley) .....	22
Adjust Trolley Width (models with trolley) .....	23
Install Trolley on Beam (models with trolley) .....	23
Supply Voltage .....	23
Operation .....	24
Qualified Operator .....	24
Handling Precautions .....	24
Recommended Operation .....	25
Hoist Setup .....	26
Parts .....	28
Exploded view and parts list .....	28
Motor and body assembly drawing .....	28
Motor and body assembly parts list .....	29
Trolley assembly drawing .....	30
Trolley assembly parts list .....	30
Inspection & Maintenance .....	32
Operation .....	32
Periodic Inspection .....	32
Recommended Operation .....	35
Pairing transmitter and receiver .....	36
Troubleshooting .....	37
During operation .....	37
Power Cable .....	39
Motor .....	39
Brake .....	40
Inside Wiring .....	40
Transformer .....	41
Contactor & Electric Reply .....	41
Limit switch .....	42
Push Button switch .....	42
Electric shock .....	43
Hook .....	43
Load pulley and empty pulley .....	43
Bearing .....	43
Trolley .....	44
Electric Trolley .....	44
Pairing transmitter and receiver .....	45

Thank you for purchasing our Prowinch® Electric Wire Rope Hoist. This User Manual provides important information for personnel involved with the installation, operation, and maintenance of this product. Read this User Manual before installing, operating, or maintaining the product.

## 1. SAFETY PRECAUTIONS

The Prowinch® Electric Wire Rope Hoist is designed for a safe and reliable service if operated according to the User Manual. Respect and follow all warnings for personnel and third party safety indications. Inadequate operation may cause serious risks of injuries to personnel or damage to the equipment. Read and understand this User Manual carefully before installing and commissioning the equipment. Always keep this User Manual in an accessible place for future reference. The compact and lightweight structure of the PWA and PWX models together with their ease of use makes them a preferred hoist for daily use in factories, mines, sea ports and

warehouses.

Improperly installed, maintained, or operated hoists can be the cause of serious accidents or death. This User Manual highlights symbols and notes for caution, warning and danger. Following these indications greatly improves the safety of the operator and personnel in the area.

### Mandatory use of:



**Hard Hat**



**Safety Glasses**



**Safety Gloves**



**Safety Shoes**

## 1.1. Hoist Safety Precautions



**WARNING:**

This symbol warns for unsafe practices or situations which may cause damage to the property and even injuries to the personnel.



**DANGER:**

This symbol indicates a potentially dangerous situation which if not avoided may cause severe injuries or death



**DANGER**

All operators and other users who are near the steel wire rope or its load must wear required safety equipment: gloves, safety helmet / hard hat, safety shoes and eye protection.



**WARNING**

Before installing, removing, inspecting, or performing any maintenance on the hoist, the main switch must be de-energized, locked out, and tagged out.  
Do not use this equipment in hazardous locations.

Read and understand the contents of this User Manual thoroughly before handling the electric wire rope hoist. Practicing correct and safe operating procedures and carrying out the recommended preventative maintenance will ensure a long, reliable, and safe service.

After a careful study and understanding of the User Manual, store it for future reference.

## 1.2. Before using the Equipment:

- Read and understand the instructions in this User Manual and all the labels associated with the hoist before operating the equipment.
- Wear appropriate clothing: Do not wear jewelry or loose clothes as they can get caught by the wire rope or hook.
- Wear leather gloves.
- Wear non-slippery safety shoes, helmet, and eye protection.
- Perform a full check of hoist. Check for damaged parts or unusual conditions.
- Keep a safe distance: suggested distance is at least 1.5 times the length the of hoist's wire rope. A broken or loose wire rope may cause injuries or death.
- Check that the hoist and wire rope are properly lubricated.
- Secure the electric wire rope hoist to a suitable support.
- Visually inspect all electric wire rope hoists before each use in addition to the regular inspections and maintenance.

### 1.3. During Operation:

#### ALWAYS:

- Refer to the maximum load capacity displayed on the ID plate attached to the hoist, not the capacity of the hook.
- Stop operation immediately if unauthorized personnel enter the working area.
- Check the working condition of hoist: If the motor gets too hot stop the hoist and let it cool down for a while.
- Stop, check, and secure the load if hoist stops or loses movement during operation.
- Focus on the operation. Pay attention at all times and keep proper balance.
- Unplug the hoist after operation.



#### NEVER:

- **Never** exceed the maximum load capacity of the hoist.
- **Never** operate a damaged or malfunctioning hoist.
- **Never** operate the hoist if it shows an abnormal behavior.
- **Never** lift, support, or transport people or loads over people.
- **Never** Walk or step on the wire rope.
- **Never** operate the electric wire rope hoist with twisted, kinked, damaged or worn load wire rope.
- **Never** use the load wire rope as a sling around load.
- **Never** operate a hoist if the ID plate or safety labels are missing or illegible.
- **Never** operate an electric hoist if exposed to rain or water.
- **Never** use if operator is sick or not completely attentive.
- **Never** leave the hoist unattended while energized or loaded.
- **Never** operate the hoist with non-centered load.
- **Never** operate beyond the limits of the load wire rope or extend wire rope.
- **Never** use the load wire rope or hook as an electrical or welding ground.
- **Never** remove the labels placed on the electric wire rope hoist.
- **Never** use the hoist to lift load at an angle, nor pull or drag load

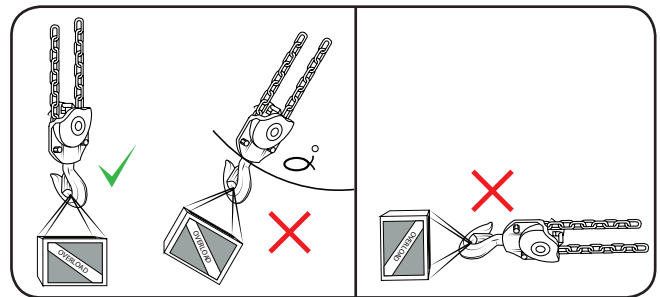

### 1.4. Inspection, Maintenance and Repairs:

- Only trained and authorized personnel may perform repairs to the equipment.
- Use only original ProWinch® parts. The use of any other part immediately voids the warranty.
- Failure to use only original ProWinch® parts may create a dangerous condition for the operator.

#### ALWAYS:

- Check the good condition of electrical connections.
- Check the wire rope and keep it lubricated.
- Prevent others from stepping under lifted load.
- Inspect and maintain the hoist regularly.
- Verify the correct installation of hoist before using.
- Avoid contact with explosive gases or materials.

#### NEVER:

- **Never** overload the hoist.
- **Never** transport people or animals with the hoist.
- **Never** stand under suspended load.
- **Never** use the hoist if exposed to rain, snow, or electrical storm.
- **Never** leave loads suspended for an extended period of time. This may cause component deformation and accidents.
- **Never** exceed the allowable operating temperatures stated in this User Manual (differs depending on the model).
- **Never** expose the hoist to water, sand, corrosive environment or other substances which may damage the equipment.

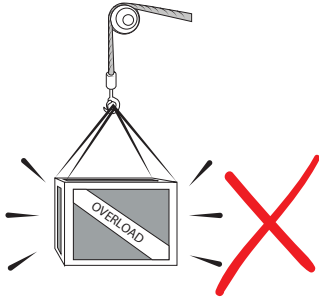

1. Do not overload.

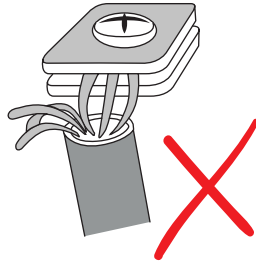

2. Check the proper crimp of the electrical connections.

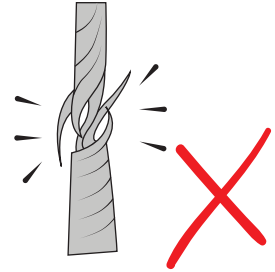

2. Periodically check the wire rope and clean it if necessary.

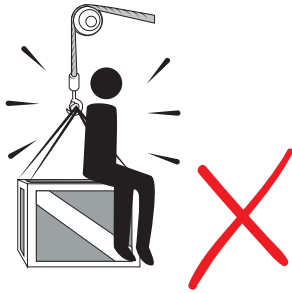

4. Do not transport people or animals with a hoist.

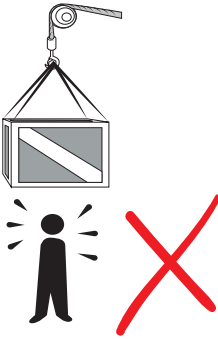

5. Do not step or walk under lifted load and prevent others from doing so.

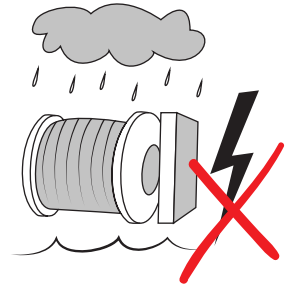

6. Do not use the hoist if exposed to rain, snow or lightning.

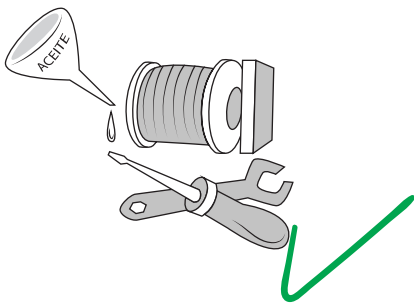

7. Inspect and maintain your hoist regularly.

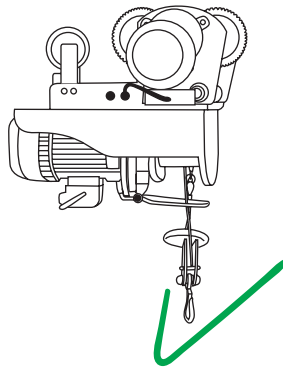

8. Always verify the correct hoist installation before use.

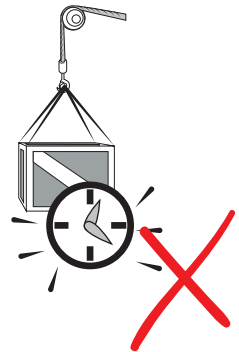

9. Do not leave the load lifted for long periods of time. It may cause deformation of the equipment and increase the risk of an accident.



Do not exceed the operating temperatures for which the hoist is designed. This range is indicated in this manual and may vary depending on the model.

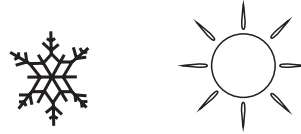

Warning:

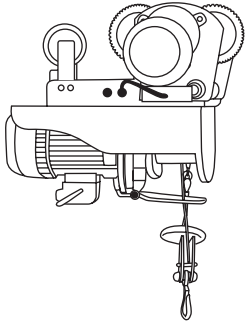

Avoid contact with gases or explosive materials.

Exposure to water, sand, a corrosive environment, or other potentially harmful elements may damage the equipment

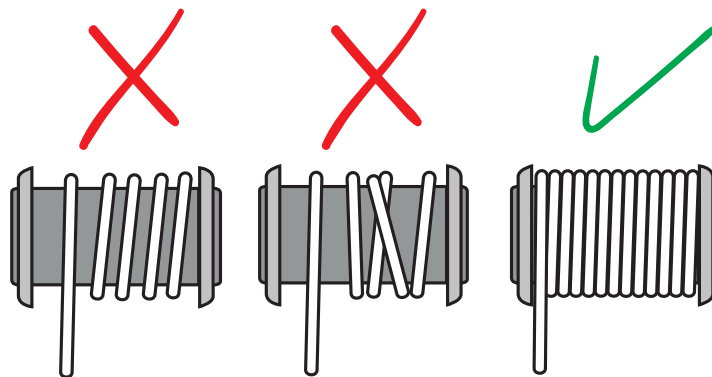
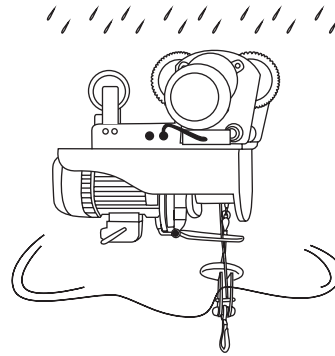
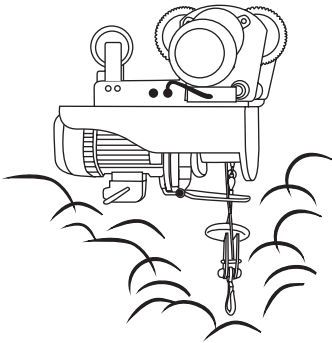

## **General precautions:**

- Make sure the Hoist is in working conditions.
- Keep the Hoist in good condition and make sure the wire rope does not protrude from the drum when winding.
- Do not use pulleys or accessories that are not compatible with this hoist.
- Do not use defective, worn or broken wire ropes.
- To reduce the risk of electric shock, make sure that the Hoist is electrically grounded by qualified electrician.
- Before Operating make sure that the hoist works properly empty, without load.
- Wind the steel cable in an orderly and uniform manner in the drum. If the steel cable starts tangling is necessary to rewind it.
- Disconnect the equipment from the power supply when not in use to avoid accidents.

## **Wear appropriate clothing:**

- Do not wear loose clothes or jewelry. They can be pulled inside the moving parts.
- Wear leather gloves when touching the wire rope. Do not touch the wire rope with bare hands since loose strands can cause serious injuries, you must wear non-slip safety shoes, safety helmet and eye protection.

## **Keep a safe distance:**

- Make sure all people are away from the wire rope and load, when the hoist is in operation it is advisable that distance is 1.5 times the length of the cable. If the wire rope is loose or broken it can whip and cause serious personal injury or death.
- Do not cross over the cable.
- It is necessary to ensure that all visitors and spectators stay away from the working area.

## **Do not abuse the Power cord:**

- Never lift the hoist by the cable or pull to disconnect.
- Move the power cord away from heat, oil and sharp edge.
- Never unwind all the cable, keep at least 5 turns in the drum.

## **Don't overuse the hoist:**

- If the engine gets very hot, stop it and let it cool down for a few minutes.
- If the hoist stops during operation, stop the operation and check the load and trolley.
- Do not exceed the maximum capacity shown in the table. The loads should not exceed those measurements.
- It is normal when stopping the hoist while a load is being lowered, it drops a few more centimeters due to the inertia force.
- It is normal that the load drops a few inches while lowering it due to inertia.

**Check the damaged parts:**

- Before using, it is necessary to check the hoist completely. An authorized Prowinch service center needs to repair or replace any part that is damaged.

**Repair the Hoist:**

- To repair, use only original Prowinch spare parts, otherwise you can put the user in danger. The use of any other spare will cause the warranty to expire or be voided. Only use accessories manufactured for this hoist.
- If the cable is worn out, it must be replaced, provided only by the original cable and produced by us in an authorized workshop.

**Wind the cable:**

- Before starting work, carefully check that the steel cable is correctly wound on the roll, with a pitch corresponding to the diameter of the cable.
- You must wear leather gloves to wind the cable. To wind correctly it is necessary to keep a small load on the cable. While the operator rolls the cable, another person should guide it in its correct location. Start from far and as center as possible. Walk with the load on the cable while the hoist rolls up.
- Keep at least three turns of cable.
- Do not allow the cable to fall and approach the hoist.
- Turn off the hoist and repeat the process until only 3 feet of cable remains.
- Disconnect the remote control and / or cut off the power supply.
- Never wind the entire cable, always leave 25 cm to avoid any danger.

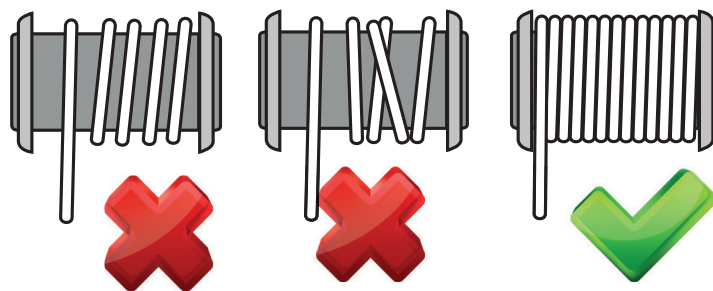
**WARNING**

Improperly connecting the grounding wire can result in the risk of electric shock. Check with a qualified electrician if you are in doubt as to whether the outlet is properly grounded. Do not modify the power cord plug provided with the tool.

Never remove the grounding prong from the plug. Do not use the tool if the power cord or plug is damaged. If damaged, have it repaired by a service facility before use. If the plug will not fit the outlet, have a proper outlet installed by a qualified electrician.

## GROUNDING UNITS: HOISTS WITH 3- PRONG PLUGS

1. Units marked with “Grounding Required” have a 3-wire cord and 3-prong grounding plug. The plug must be connected to a properly grounded outlet. If the unit were to electrically malfunction or break down, grounding provides a low resistance path to carry electricity away from the user, reducing the risk of electric shock. (See Figure A.)

2. The grounding prong in the plug is connected through the green wire inside the cord to the grounding system in the tool. The green wire in the cord must be the only wire connected to the hoist’s grounding system and must never be attached to an electrically “live” terminal. (See Figure A.)

3. Your unit must be plugged into an appropriate outlet, properly installed and grounded in accordance with all codes and ordinances. The plug and outlet should look like those in the following illustration. (See Figure A.)

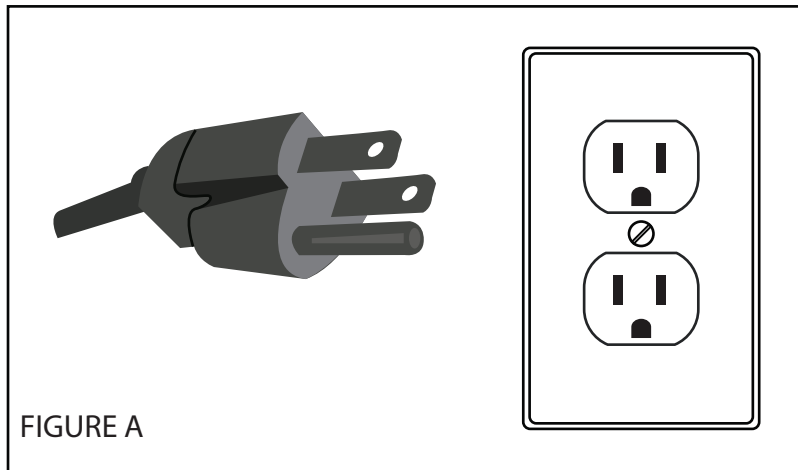

## DOUBLE INSULATED UNITS: HOISTS WITH 2-PRONG PLUGS

4. Units marked “Double Insulated” do not require grounding. They have a special double insulation system which satisfies OSHA requirements and complies with the applicable standards of Underwriters Laboratories, Inc., the Canadian Standard Association, and the National Electrical Code. (See Figure B.)

5. Double insulated tools may be used in either of the 120-volt outlets shown in the following illustration. (See Figure B.)

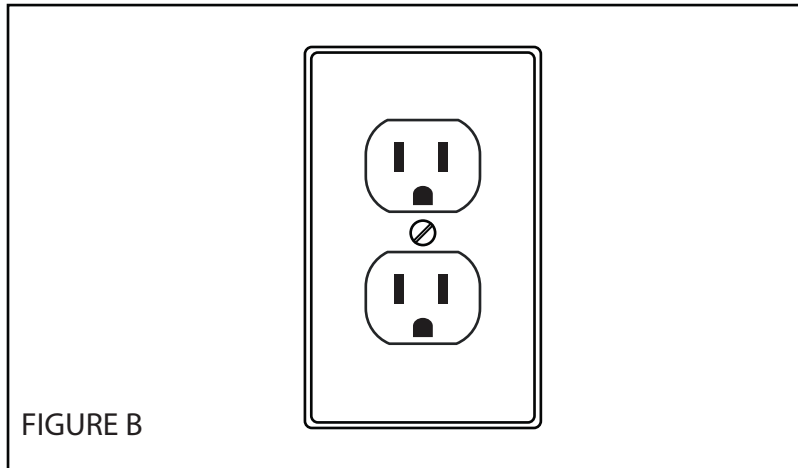

## EXTENSION CORDS

1. Grounded hoists require a 3-wire extension cord. Double Insulated tools can use either a 2- or 3-wire extension cord.
2. As the distance from the supply outlet increases, you must use a heavier gauge extension cord. Using extension cords with inadequately sized wire causes a serious drop in voltage, resulting in loss of power and possible unit damage.
3. The smaller the gauge number of the wire, the greater the capacity of the cord. For example, a 14- gauge cord can carry a higher current than a 16- gauge cord.
4. When using more than one extension cord to make up the total length, make sure each cord contains at least the minimum wire size required.
5. If you are using one extension cord for more than one tool, add the nameplate amperes and use the sum to determine the required minimum cord size.
6. If you are using an extension cord outdoors, make sure it is marked with the suffix "W-A" ("W" in Canada) to indicate it is acceptable for outdoor use.
7. Make sure your extension cord is properly wired and in good electrical condition. Always replace a damaged extension cord or have it repaired by a qualified electrician before using it.
8. Protect your extension cords from sharp objects, excessive heat, and damp or wet areas.

## 2. SPECIFICATIONS

### 2.1. Product Code.

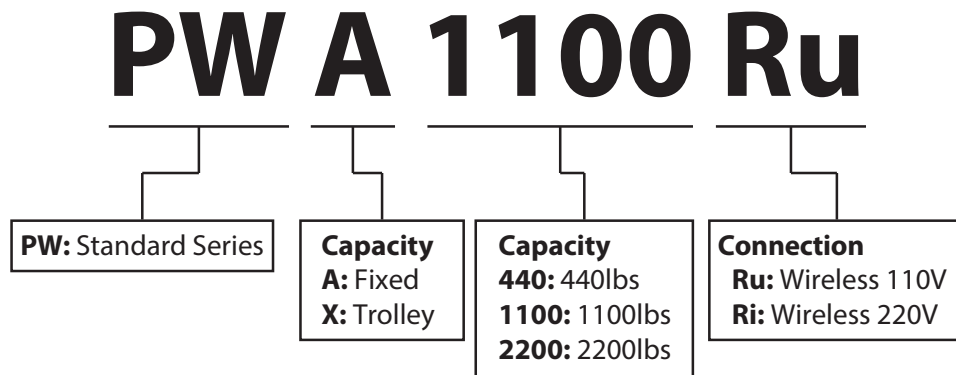

### 2.2. Specification Chart (Prowinch® Electric Wire Rope hoists).

Item	Specs
Operating temperature range (°C)	-20° to ± 40°
Operating Humidity Range (%)	< 85%
Protection Class	IP40
Hoist	IP65
Remote Control	IP65
Power	3 Phases, 200V - 600 V, 50/60Hz
Noise Level (db)	81db
Single Speed Hoist	81db
Double Speed Hoist	81db

### Observations

Do not use Prowinch® Electric Wire Rope Hoists when the temperature or humidity exceeds the range stated in the Specification Chart.

Our hoists are designed to lift loads vertically under normal atmospheric and working conditions.

### 2.3. Load Level and Service Life

Hoist Duty Class	Typical Areas of Application	Operational Time Ratings at K = 0.65			
		Uniformly Distributed Work Periods		Infrequent Work Periods	
		Max. On Time, min/hr	Max. No. Starts/hs	Max. No. Time From Cold Start	Max. No. of Starts
H1	Powerhouse and utilities, infrequent handling. Hoists used primarily to install and service heavy equipment, where loads frequently approach rated load, and where the hoist is idle for 1- to 6-month periods between periods of operation.	7.5 (12.5%)	75	15	100
H2	Light machine shop, fabricating service, and maintenance. Loads and utilization randomly distributed. Rated loads infrequently handled. Total running time not more than 12.5% of the work period.	7.5 (12.5%)	75	15	100
H3	General machine shop, fabricating, assembly, storage, and warehousing. Loads and utilization randomly distributed. Total running time not more than 25% of the work period.	15 (25%)	150	30	200
H4	High-volume handling of heavy loads, frequently near rated load in steel warehousing, machine and fabricating shops, mills, and foundries, with total running time not more than 50% of the work period. Manual or automatic cycling operations of lighter loads with rated loads infrequently handled such as in heat treating and plating operations, with total running time frequently 50% of the work period.	30 (50%)	300	30	300
H5	Bulk handling of material in combination with buckets, magnets, or other heavy attachments. Equipment often cab operated. Duty cycles approaching continuous operation are frequently necessary. User must specify exact details of operation, including weight of attachments.	60 (100%)	600	N/A	N/A

Working Conditions		Load	Time	Maintenance Interval (Months)	Expected Life [Working Hours]				
					800	1600	3200	6300	12500
Light	Light Mechanisms subjected normally to light loads and very rarely to the maximum load.			6 - 12	H1	H2	H3	<b>H4</b>	<b>H5</b>
Normal	Mechanisms subjected normally to moderate loads and frequently to the maximum load.	< 65%	< 25%	6 - 12	H2	H3	<b>H4</b>	<b>H5</b>	
Heavy	Mechanisms subjected normally to loads of heavy magnitude and frequently to the maximum load.	> 65%	> 25%	3 - 6	H3	<b>H4</b>	<b>H5</b>		
Severe	Mechanisms subjected regularly to the maximum load	Abnormal conditions Environmental, Geographical, etc <100% < Duty Cycle Limit		1 - 3	<b>H4</b>	<b>H5</b>			



## 2.4. Electric wire rope hoist Specifications.

Modelo / Model	PWA440Ru	PWA1100Ru	PWA2200Ru	PWX440Ru	PWX1100Ru	PWX2200Ru				
<b>HOIST / POUFASO</b>	<b>Capacity</b> Capacidad		220 lb 1 line / 440 lb 2 lines 100 kg 1 línea / 200 kg 2 líneas	550 lb 1 line / 1100 lb 2 lines 249 kg 1 línea / 500 kg 2 líneas	1100 lb 1 line / 2200 lb 2 lines 500 kg 1 línea / 1000 kg 2 líneas	220 lb 1 line / 440 lb 2 lines 100 kg 1 línea / 200 kg 2 líneas	550 lb 1 line / 1100 lb 2 lines 249 kg 1 línea / 500 kg 2 líneas	1100 lb 1 line / 2200 lb 2 lines 500 kg 1 línea / 1000 kg 2 líneas		
	<b>Speed (per min)</b> Velocidad (por min)		33 ft 1 line / 33 ft 2 lines 10 m 1 línea / 5 m 2 líneas							
	<b>Lifting Height</b> Altura de Elevación		33 ft 1 line / 33 ft 2 lines 11.5 m 1 línea / 5.7 m 2 líneas							
	<b>Motor Power</b> Potencia de Motor		400W	1000W	1450W	400W	1000W	1450W		
	<b>Rated Volt</b> Voltaje Nominal		110V/120V @ 60 Hz							
	<b>Rated Current</b> Corriente Nominal		4.1 A	8.5 A	12.5A	4.1 A	8.5 A	12.5A		
	<b>Insulation Grade</b> Grado Aislamiento		Class B							
	<b>Traveling Speed (per min)</b> Velocidad de Traslado (por min)		Not included / No incluido 52 ft / 16 m							
	<b>Trolley Motor Power</b> Potencia Motor-Carri		Not included / No incluido			110/120V @ 60 Hz 220 W				
	<b>I Beam Width</b> Ancho de la Viga I		Not included / No incluido			2 ~ 4.5 in / 50 ~ 114 mm (optional duct available for wider beams) (opc. optional para vigas mas anchas)				
<b>Wheel Diameter</b> Diámetro de la Rueda		Not included / No incluido			3.3 in / 85 mm					
<b>Min. Turn Radius</b> Radio Mínimo de Giro		Not included / No incluido			2.62 ft / 0.8 m					
<b>Net Weight</b> Peso Neto		Not included / No incluido			30 lb / 13 KG					
<b>Packing Dimension</b> Dimensión de empaque		Not included / No incluido			14x12x8 in / 350x300x200 mm					
<b>Total Weight</b> Peso Total		Not included / No incluido			33 lb / 15 kg					
<b>TROLLEY / CARRIO</b>	<b>Wire Rope Diameter</b> Diámetro Cable		ø 1/8 in   ø 3 mm	ø 11/64 in   ø 4.3 mm	ø 7/32 in   ø 5.58 mm	ø 1/8 in   ø 3 mm	ø 11/64 in   ø 4.3 mm	ø 7/32 in   ø 5.58 mm		
	<b>Wire Rope Tensile Strength</b> Resistencia del Cable a la tracción		≥ 1870N/mm <sup>2</sup>		≥ 1770N/mm <sup>2</sup>		≥ 1870N/mm <sup>2</sup>		≥ 1770N/mm <sup>2</sup>	
	<b>Operation Temperature</b> Temperatura Operación		-4° ~ 104° F / -20° ~ 40° C							
	<b>Operating Humidity</b> Humedad de Operación		≤85%							
<b>Enclosure Protection Class</b> Clase de protección de aislamiento		IP40								
<b>Noise Level</b> Nivel de ruido		71 dB								
<b>GENERAL</b>	<b>Net Weight</b> Peso Neto		40 lb / 22 kg	74 lb / 34 kg	73 lb / 33 kg	77 lb / 35 kg	104 lb / 47 kg	101 lb / 46 kg		
	<b>Total Weight</b> Peso Total		52 lb / 24 kg	76 lb / 36 kg	75 lb / 34 kg	86 lb / 39 kg	112 lb / 51 kg	108 lb / 49 kg		
	<b>Packing Dimension</b> Dimensión de empaque		18x14x8 in 460x360x200 mm	20x17x6 in 510x440x170 mm	22.2x9.8x12.7 in 560x250x125 mm	18x14x8 in 460x360x200 mm	20x17x6 in 510x440x170 mm	22.2x9.8x12.7 in 560x250x125 mm		
	<b>Duty Class</b> Clase de Servicio		HST H1							
	<b>Standards</b> Normas		ETL/CETL approval							

## 2.5. Oil & Lubricant Recommendations



### WARNING

Do not allow wire rope to run dry.

Lubricant greatly increases the life of wire rope. Weekly lubrication and cleaning is satisfactory, but under hot, dirty, and extreme conditions it may be necessary to clean the wire rope at least once a day and lubricate it several times between cleaning.

Suspension pins should be lubricated at least twice per year for normal usage; more frequently for heavier usage or severe conditions.

Item	Lubricant	Interval	
		Normal Working Conditions	Heavy / Severe Working Conditions
Wire rope	Lubriplate® Bar and Chain Oil 10-R	Weekly	Daily
	Gear Oil ISO46 – ISO68	Twice Weekly	Daily
Gearbox	Meropa 320 (TEXACO)	Twice per year	Every other month
Hooks, Suspension pins & components	General lithium grease	Weekly	Daily

### 3. INSTALLATION

---



#### WARNING

Before installing, removing, inspecting, or performing any maintenance on the hoist, the main switch must be unplugged, locked out, and tagged out. Do not use this equipment in hazardous locations.

Installation Process:

- Electric wire rope hoists must be grounded properly.
- Lock-out, tag-out, and unplug the hoist before performing any service.
- Customer must provide power supply cable, fuses, and main disconnect switch.
- Check supply voltage is same as nameplate voltage on hoist.
- Ensure that the voltage does not vary by more than  $\pm 10\%$  from nominal value.
- Do not use conductors smaller than those listed in this User Manual to supply power to hoist.
- Never bypass limit switches, remove limit switch stops, or alter limit switch devices.

### 3.1 Unpacking

Hoist should be carefully inspected upon delivery for any damage that may have occurred during shipment or handling. Check the hoist frame for: dents or cracks, external cords for damaged or cut insulation, control station for cut or damaged enclosure, and wire rope for twists, loops or broken strings.

Check and document hoist characteristics:

- a. Model number
- b. Rated capacity (tonnage)
- c. Lifting length of wire ropes (meter)
- d. Power supply
- e. Push button pendant assembly (2 button, 4 button or 6 button)
- f. Specially ordered optional items
- g. Beam width for trolley installation

## 3.2. Electrical Connections

Operator and/or owner must provide main power supply hardware (cable, conductor bar, fuses, disconnect switch, etc.)



### WARNING

Fuses and other current overload devices must be in place to protect power supply.

Do not use power supply cables with solid conductors.

An improper or insufficient ground connection creates an electrical shock hazard when touching any part of hoist or trolley



### 3.3. Install Trolley (models with trolley)

- 1.- Insert suspension pins into lateral plate G and lock it with suspension pin bolts and nuts.
- 2.- Install suspension pin with adjusting disk.
- 3.- Install suspension pin into hanger T. The nameplates of hoist and trolley should be in the same direction.
- 4.- Install additional gaskets into suspension pin before inserting it into lateral plate S.
- 5.- Install outside adjusting disk and spacer pin into suspension pin. Insert cotter pin into spacer pin.
- 6.- Cotter pin should be seen at the left side from front of trolley switch box.

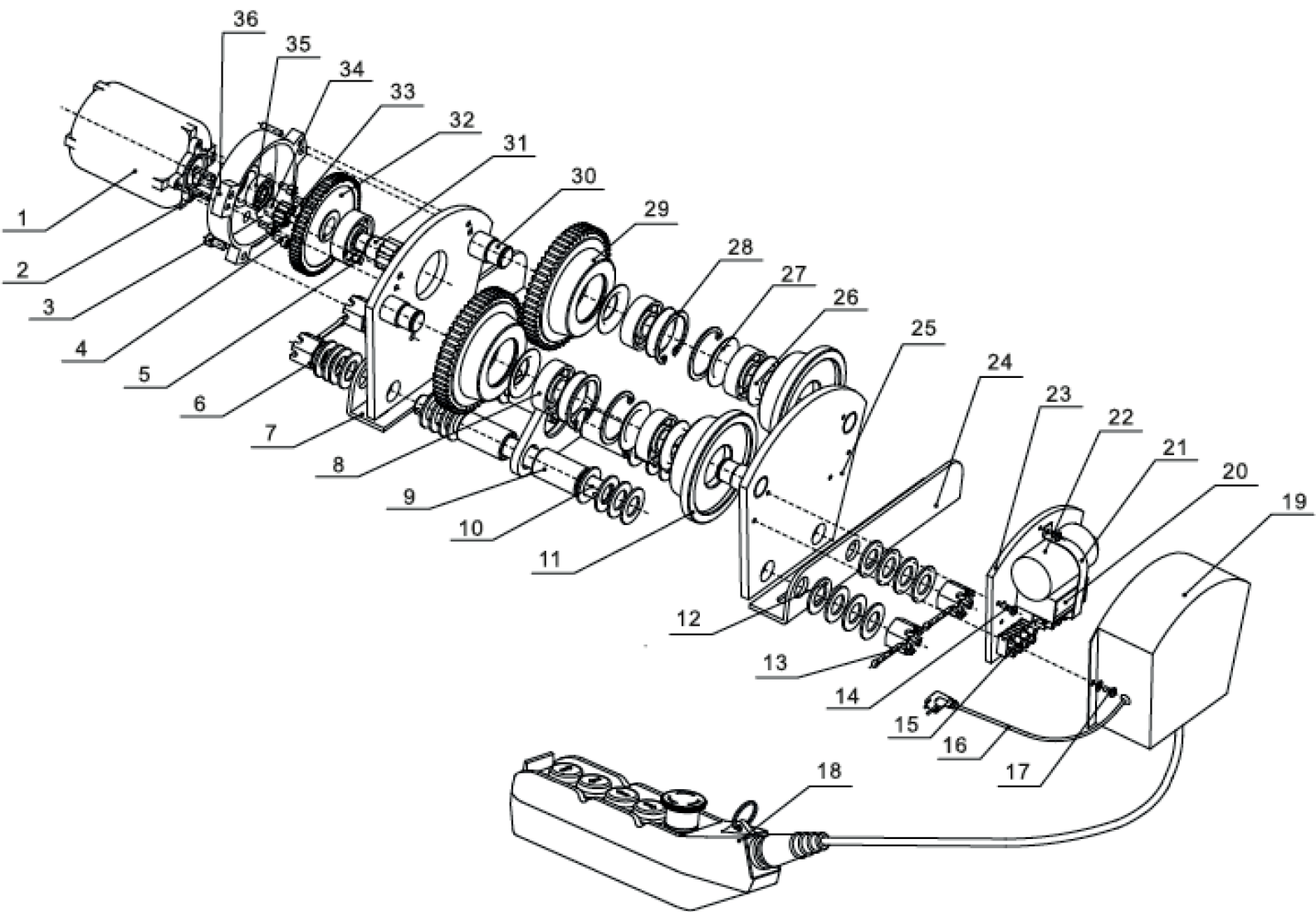

## 3.4. Adjust Trolley Width (models with trolley)

- Adjust width of trolley according to drawing (right) for appropriate clearance.
  - Size A is the dimension of two side plates that stretch outside completely.
  - Size A must be approximate B (the width of rail flange) + 4mm.
  - Adjust size A by increasing or decreasing adjusting disk.
- Insert cotter pin into spacer pin and bend two branches of cotter pin until size A is correct.

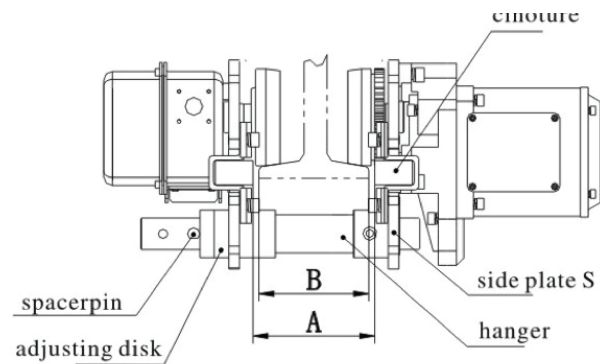

Nut must be tight, insert cotter pin and bend it completely.

## 3.5. Install Trolley on I-Beam (models with trolley)

1. Install trolley at end side of beam and slip trolley which has already been connected with hoist to the appropriate place. This is the preferred method.

2. If first method is unavailable:

- Unload brake stopper from hole A on suspension pin, and insert it into hole B. Insert cotter pin again and bend it completely.
- Pull side plate S and G outside, then lift trolley until orbit wheel and orbit surface are in same horizontal position. Put orbit wheel of side plate G onto surface of orbit.
- Hold side plate G and stop it from dropping from orbit. Firmly push side plate S and put its orbit wheel onto surface of beam.
- Unload brake stopper from hole B and insert into hole A. Do not forget to bend cotter pin.

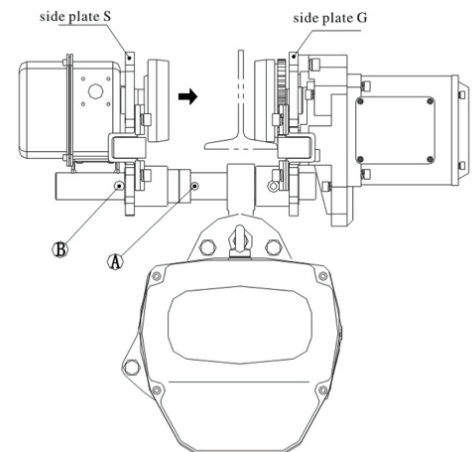

## 3.6. Supply Voltage



### WARNING

Check supply voltage everyday before use. If voltage varies more than 10% of rated value, electrical devices may not function normally and cause damage to equipment.



### WARNING

Do not connect equipment to power supply before completing the installation process.

## 1. OPERATION

---

### 1.1. Qualified Operator

Hoist operators are required to read and fully understand the operation section of this manual, all warnings contained in the manual, and labels attached to the equipment.

Operator training must be provided to ensure proper operation of equipment in compliance with instructions provided by the equipment manufacturer and the provisions of ASME B30, and proper rigging procedures for the attachment of loads to the hoist.

A safe and efficient operation of hoist requires an operator who exercises caution, common sense, and good judgment in anticipating the effects of operating the hoist. The operator must be fully alert, focused, and aware of the surroundings at all times.

The job must be strictly carried out under the good practices defined by the applicable international and national safety standards, such as ANSI, OSHAS and ASME.

**This hoist must not be operated by someone who:**

- Cannot read, understand and speak the language in which the security labels, ID Plate and User Manual of equipment is written.
- Does not meet the legal age requirements.
- Is under the influence of alcohol, drugs, or medication.
- Has visual or hearing impediments, or below normal reaction times.
- Has a history of or experiences seizures, mental, heart, or other illnesses that could interfere with a safe operation of the equipment.
- Has not been trained for the proper use of the hoist.
- Has not received and read the User Manual for the exact equipment.
- Has not demonstrated qualifications through a practical operation of hoist.

### 1.2 Handling Precautions

**ALWAYS:**

- Keep hoist in good condition and make sure wire rope is lubricated and free to operate.
- Make sure electrical connection is grounded.
- Make smooth movements; avoid sudden changes of directions.
- Check functions of hoist and trolley without any load before operation.
- De-energize equipment after using it to avoid unintentional operation.
- Keep everyone a distance of at least 1.5 times the length of wire rope. If load falls it can cause serious injuries and death.
- Make sure no one is beneath load.

**NEVER:**

- Use pulleys or other accessories that are not specifically approved for relevant hoist model.
- Hoist load with tip of hook.
- Hoist load which is not vertical to hook.
- Use hoist to pull or drag load.
- Exceed maximum capacity of hoist.

## 1.3 Recommended Operation



### WARNING

Always carry out a complete inspection before starting the operation of the hoist.

See ASME B30.

Always let know to all personnel that crane maneuvers are about to begin!

Do not allow Unauthorized Personnel to be in the elevation area.

Start with Operational Test

1. Turn on the remote control and press and hold the start key until you see a green light flashing on the receiver.
2. Press (down) button to lower the unloaded hook until the limit spring touches the limit switch. Be sure the hoist stops automatically before totally compressing the spring.
3. Press (up) button to raise the unloaded hook up until the limit spring touches the limit switch. Be sure the hoist stops automatically before totally compressing the spring.
4. Test correct function of emergency stop button. When pressing (up), and (down) buttons press the emergency stop button. Ensure the hoist stops immediately after pressing the emergency stop switch. The hoist should not start again if any other button is pressed.
5. Rotate the emergency stop switch clockwise to its original position. When it bounces back, the hoist can be started again. If any of the above tests fail, the unit must remain out of service, lockout/tag-out power and request authorized personnel to check the circuit layout for the automatic locking emergency stop switch.
6. Check lubricant condition of the load chain. Apply lubricant into the chain bag to protect the load chain.

Normal Operation

1. Check the direction of chain eyes. All welding points should face the same direction. The hoist cannot be operated properly unless all welding chain eyes are in the same line.
2. Position the hoist vertical to the load. Before moving the trolley, make sure the hook's path is free from any obstacles.
3. Lower the hook near master link to hoist load and make final adjustments to secure a 90° vertical lift operation without any lateral deviation. Improper lift angle may cause the load to swing.
4. Attach the hook to the load link and make sure there are no people in the working area. Check that no loose items can fall from the load.
5. Begin by hoisting the load two inches, then stop. Ensure the brakes are fully operational and the load doesn't lower while stopped. Also ensure the load is balanced and secured. The load may have shifted when suspended.
6. To reach a desired position, movements must be smooth and continuous. Repeatedly pressing buttons may heat up the motor and damage equipment.
7. Avoid sudden directional changes. These movements may damage the equipment, prematurely wear down brakes and cause accidents.



### WARNING

If hoist model has double dual/speed capabilities, always start with slower speed to avoid sudden accelerations. Decelerate before completing a stop.

8. Avoid any obstacles while hoisting or traveling the load.
9. Start movement of the trolley and ensure that the load is not swinging and there are no obstacles in its path. Stop movement and make necessary adjustments if one of these conditions is present.



10. Once the desired position is reached, slowly stop the trolley. Position the load completely vertical to the desired spot where load will be lowered.
11. Gradually lower load until it is secured on resting surface. Avoid hitting surface at high speed. If necessary, stop movement before reaching surface and gradually lower to land load.

**DANGER**

NEVER leave load suspended without attention of the hoist operator!

## 1.4 Hoist Setup

**WARNING**

Disconnect unit from power before installation.

1. This Hoist is designed to be attached to a beam or steel pipe and be securely held in place by both of the Hangers (#23).

Note: The beam or steel pipe must be capable of carrying several times the weight of the Hoist and its designated maximum capacity. If in doubt, consult a registered engineer and building code.

Note: Make sure the area underneath or around the Hoist is clear of obstructions. Do not Hoist loads over people or animals.

2. After determining the location of the Hoist, make sure the beam or pipe is the proper size to fit inside of the Hangers (#23). Have a second person hold the top of the hoist flush against the beam or pipe. Line up the holes on each Hanger (#23) with the holes on the top of the Hoist. Thread in the two Screws (#21) and Washers (#20) per Hanger (#23) to secure the Hoist to the Beam or Steel Pipe. Check that it is secure. Before each use, check that the Hangers (#23) are securely fastened to the Hoist.

3. Ideally, the Hoist needs to be set-up within a reachable distance to a 3- prong power outlet without the need of an extension cord. However, extension cords are safe and acceptable when properly used.

**WARNING**

The Wire Rope (#56) must flow through the Wire Rope Guard (#29), and the Stopper (#31) must be securely attached to the end of the Cable (#56).

1. Plug in the unit and press the Switch (#43) toward the “down” position to lower the Hook (#34) to the load.
2. When connecting the Hook (#34) to the load, you must be sure that the connection point on the load is capable of holding the weight of the entire load. If you are not sure, use a separate cable (not included) that is rated above maximum lift load capacity, to surround the unit and tie it off securely. Then, attach the load is completely inside of the hook and safety tab on the Hook (#34) and the load is centered under the hoist. The safety tab on the hook must latch or close over the connection point or cable or the load may fall causing serious damage and injury.
3. Make sure no people or animals are near the immediate area. Never support a load over people or animals.
4. Standing clear, push the Switch (#43) toward the “lift” position. Slowly raise the load only enough to clear the floor or support and check to be sure the load is securely fastened. Proceed only after you are ensured the load is secure and free of all obstructions. If the Hoist refuses to lift the load you might have exceeded maximum lift capacity. If you are under the maximum capacity and the Hoist stops on its own, release the lift switch and stay clear while the motor has sufficient time to cool down. Then, resume the process.
5. When you are ready to lower the load, press the Switch (#43) toward the “down” position.
6. When the load is completely on the ground, keeping clear of it, shake or move the load to make sure it is sitting firmly on the ground. Then, remove the Hook (#34) from the load.
7. Push the Switch (#43) toward the “lift” position and bring the Stopper (#31) up to within a few inches of the Guard (#29).
8. When finished, unplug the unit.

## 1. ELECTRIC WIRE ROPE HOIST EXPLODED VIEW AND PARTS LIST

### 1.1 Motor and body assembly drawing

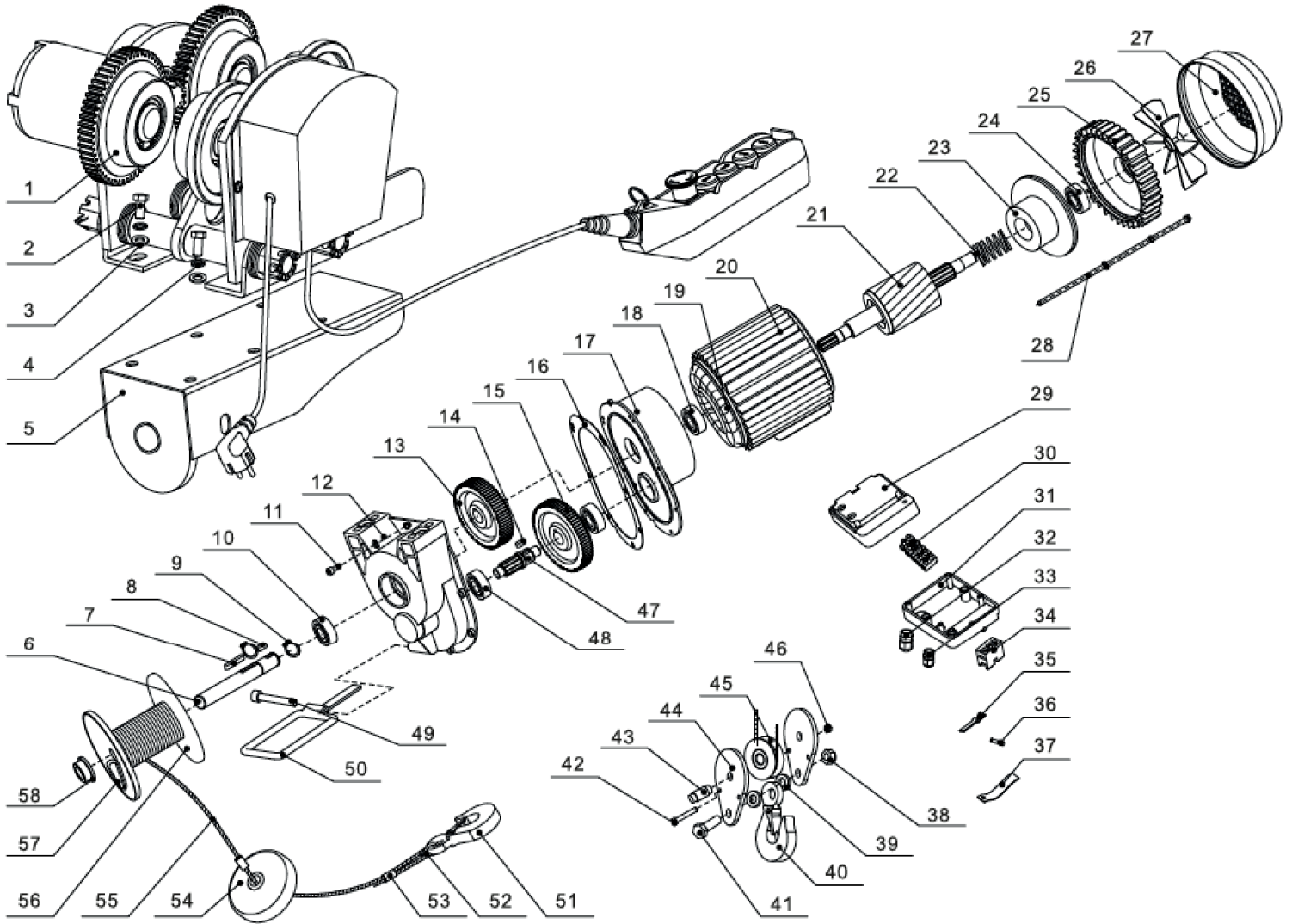

## 1.2 Motor and body assembly parts list

No.	Part Name	No.	Part Name
1	Traction Wheels	30	Terminal
2	Hexagon bolt	31	Cover
3	Flat washer	32	Holding fixture
4	Spring washer	33	Holding fixture
5	Support Structure	34	Safety switch
6	Rope roll shift	35	Breaker contactor
7	Flat key	36	Locating pin
8	Flat key	37	Spring tab
9	Elastic collar	38	Locknut
10	Bearing	39	Hook washer
11	Hexagon fillister head screw	40	Hook
12	Gear case	41	Hexagon Bolt
13	Gear	42	Hexagon Bolt
14	Flat washer	43	Wheel axle
15	Gear wheel	44	Splint
16	Cushion board	45	Pulley
17	Front cover	46	Hook fixed nut
18	Bearing	47	Gear Shaft
19	Stator	48	Bearing
20	Stator cover	49	Hexagon bolt
21	Rotor	50	Limiter
22	Tripping spring	51	Hook
23	Brake Component	52	Rope thimble
24	Bearing	53	Aluminum pipe
25	Aft closure	54	Block
26	Fan	55	Wire rope
27	Fan cover	56	Rope roll
28	Hexagon bolt	57	Wedge
29	Junction box	58	Bushing

## 1.4 Trolley assembly drawing

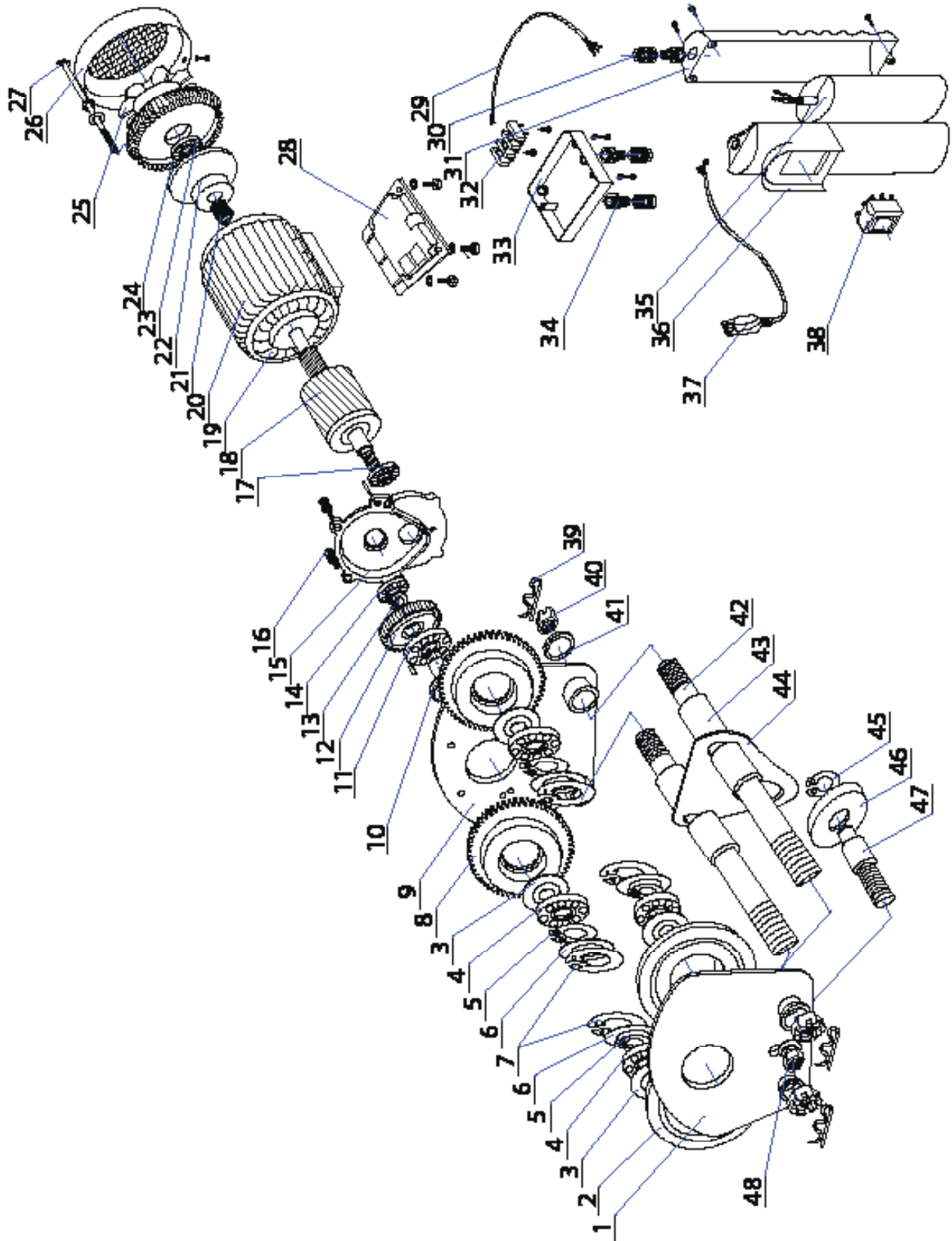

## 1.5 Trolley assembly parts list.

No.	Part Name	No.	Part Name
1	Cover fan	31	Stopper
2	Impeller	32	Clamp
3	Shield	33	Connector
4	Stator	34	Hook
5	Screw	35	Bearing
6	Bearing	36	Pinion
7	Basket	37	Key
8	Hub	38	Connector
9	Hub Gasket	39	Switch / Cable
10	Spring	40	Spring
11	Shaft	41	Screw
12	Bearing	42	Cover
13	Flange	43	Switch
14	Gasket	44	Screw
15	Bushing	45	Grip
16	Wheel	46	Condenser
17	Bearing	47	Grip
18	Crankcase	48	Screw
19	Support	49	Screw
20	Washer	50	Cable
21	Screw	51	Clamp
22	Screw	52	Terminal
23	Hanger	53	O-ring
24	Key	54	Cable
25	Shaft	55	Cable
26	Spool	56	O-ring
27	Cable	57	Clip
28	Bushing	58	Cable
29	Guard	59	Wheel
30	Screw		

## 1. OPERATION

---

### 1.1. Periodic Inspection



#### WARNING

After checking all the requirements necessary to run this unit (hertz, amps, volts) printed in the side label of this unit, you may start using it. In case that you need an extension cord please follow the directions in reference to the thickness and length of the cable.



#### WARNING

The electrical installation should meet the requirements for the peak consumption.

Note: Check the breaker threshold.

#### Inspection:

1. Periodically check the status of the wire rope.
2. Check and tighten the bolts and nuts.
3. Periodically check the correct functioning of the emergency stop.



#### WARNING

It is sole responsibility of the user to periodically check the wire rope, anchoring or any other part that may be damaged or worn out.

Items	Inspection Method	Standards		Correction	
Limit switch	Check by pushing button	Operate until upper and lower limit cause automatic motor shutdown		Replace limit switch, disassemble and clean limit lever	
Movement confirmation	Check by pushing button	-Wire rope can roll up easily -Motor shutdown immediately when operation stops -All movements shutdown when E-stop button pushed -Other buttons cannot cause movement when pushing the E-stop button -All movements return to normal operation when E-STOP button relieved			
Brake	Check by pushing button	Brake quickly activates and operation of bottom hook immediately stops (amount of movement of the load wire rope is within 2 to 3 rings)			
Limit Spring	Visual inspection and measure dimensions	Wire rope	Length of spring		Replace limit spring 
			Standard	Limits	
		∅6.3	145	140	
		∅7.1	145	140	
		∅10.0	135	129	
∅11.2	160	152			

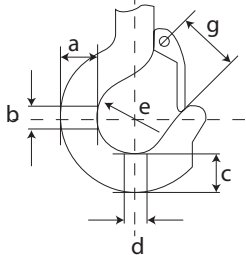
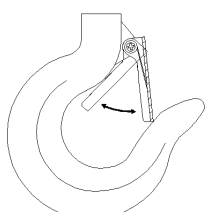

Items	Inspection Method	Standards	Correction																																																															
Attrition and opening of the hook	Visually check and with vernier caliper tool 	No remarkable opening or attrition <table border="1" data-bbox="698 315 1234 672"> <thead> <tr> <th>Load</th> <th>a</th> <th>b</th> <th>c</th> <th>d</th> <th>e</th> <th>g</th> </tr> </thead> <tbody> <tr> <td>0.3 -0.5</td> <td>27</td> <td>18</td> <td>25</td> <td>17</td> <td>35</td> <td>28</td> </tr> <tr> <td>1</td> <td>34</td> <td>24</td> <td>30</td> <td>24</td> <td>42</td> <td>32</td> </tr> <tr> <td>2</td> <td>46</td> <td>29</td> <td>39</td> <td>30</td> <td>49</td> <td>40</td> </tr> <tr> <td>3</td> <td>56</td> <td>35</td> <td>49</td> <td>34</td> <td>59</td> <td>48</td> </tr> <tr> <td>5</td> <td>67</td> <td>43</td> <td>67</td> <td>44</td> <td>60</td> <td>48</td> </tr> <tr> <td>7.5 - 10</td> <td>82</td> <td>55</td> <td>80</td> <td>48</td> <td>85</td> <td>80</td> </tr> <tr> <td>15</td> <td>110</td> <td>78</td> <td>120</td> <td>80</td> <td>120</td> <td>90</td> </tr> <tr> <td>20 - 25</td> <td>142</td> <td>95</td> <td>155</td> <td>98</td> <td>150</td> <td>115</td> </tr> </tbody> </table>	Load	a	b	c	d	e	g	0.3 -0.5	27	18	25	17	35	28	1	34	24	30	24	42	32	2	46	29	39	30	49	40	3	56	35	49	34	59	48	5	67	43	67	44	60	48	7.5 - 10	82	55	80	48	85	80	15	110	78	120	80	120	90	20 - 25	142	95	155	98	150	115	
		Load	a	b	c	d	e	g																																																										
		0.3 -0.5	27	18	25	17	35	28																																																										
		1	34	24	30	24	42	32																																																										
		2	46	29	39	30	49	40																																																										
		3	56	35	49	34	59	48																																																										
		5	67	43	67	44	60	48																																																										
		7.5 - 10	82	55	80	48	85	80																																																										
		15	110	78	120	80	120	90																																																										
20 - 25	142	95	155	98	150	115																																																												
Deformation, damage and corrosion	Visual check	No remarkable deformation, harmful damage and corrosion	Replace hook																																																															
Hook safety block	Visual inspection, fold and unfold actions	-Can exactly fold inside the hook -No deformation Dangerous -Do not use hook if safety block is loosening Improper use will lead to death or serious injury	Replace hook safety block 																																																															
Hook movements (rotate)	Visual inspection and manual rotation	-No remarkable space between bottom supporting and top -equal at right and left -easy to rotate 360°	Replace hook																																																															

## 1.2 Recommended Operation



### WARNING

Before each use, inspect the general condition of the hoist. Check for loose screws, misalignment or binding of moving parts, cracked or broken parts, damaged electrical wiring, and any other condition that may affect its safe operation. If abnormal noise or vibration occurs, have the problem corrected before Further use. Do not use damaged equipment.

1. Wipe the Hoist down with a lint free cloth.
2. Check the cable for tears, excessive wearing, damage or frays. If you find any, do not use the Hoist until the cable is replaced by a qualified technician. Only use genuine replacement cable (Cable (#56)). Do not substitute rope or any other type of cable.
3. Periodically lubricate the cable with a light oil.

## Pairing transmitter and receiver

### Follow these instructions to pair the transmitter:

1. Disconnect the power supply from the receiver.
2. Remove the battery from the transmitter.
3. Return the battery to the transmitter, then hold down the “up” and “start” buttons until the Red LED on the transmitter flashes rapidly.
4. Re-connect the receiver to the power supply. The red LED on the transmitter will begin to flash slower. At this point, the transmitter and receiver are paired.

### If you need to change the code and channel on the transmitter, complete one of the following:

TO COPY TRANSMITTER CODE AND CHANNEL TO THE RECEIVER  
Press “UP” key to complete this operation.

TO COPY RECEIVER CODE AND CHANNEL TO THE TRANSMITTER  
Press “DOWN” key to complete this operation.

If the process has been successful, the green LED on the transmitter will flash once.

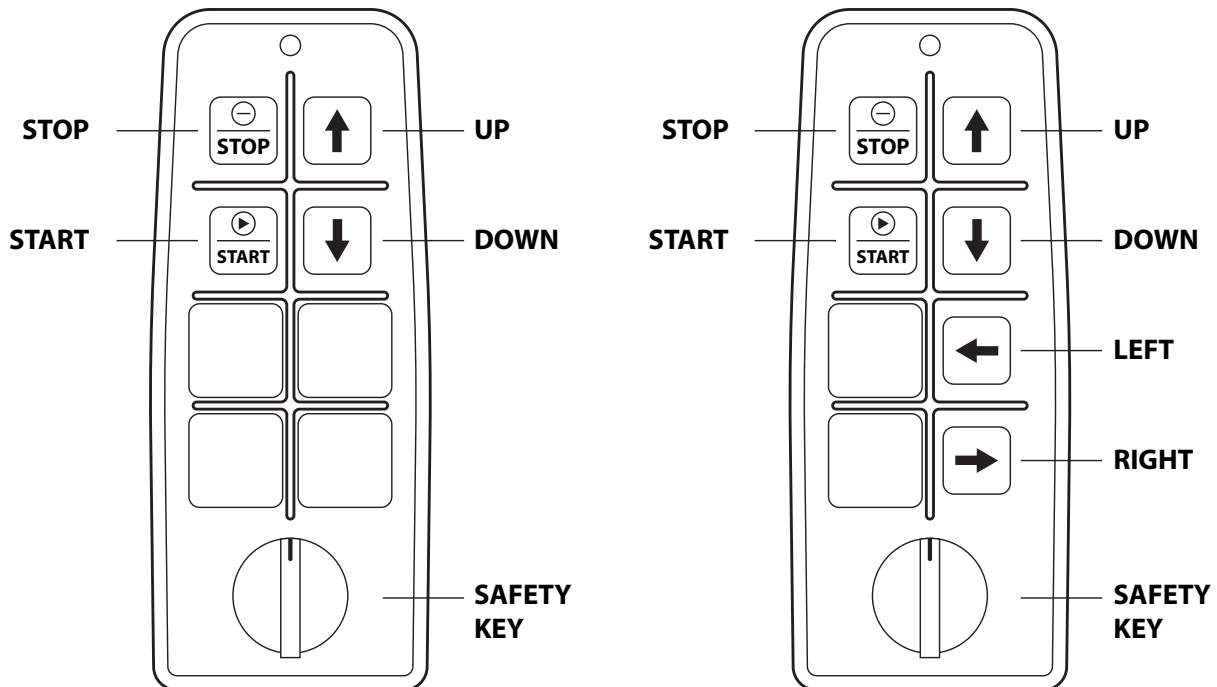

## 7.1. During Operation:

Symptoms		Main Cause	Correction
Hoist does not operate	Brake is inaudible	Excessive voltage	Power
		Operating circuit break-off, electric parts over-heating	Power supply
			Internal wiring
			Contactor
			Transformer
			Up/Down limit switch
	Button switch		
	Contactor is audible	Power circuit break-off, overheating motor, brake	Motor
			Brake
			Internal wiring
Contactor (junction fusing)			
Brake is audible		Drive overheating, broken bearing	Gear
			Bearing
Operates without load only	Unable to lift (motor roar)	Default phase (single phase operation)	Power
			Feed power
			Motor
Slow lifting		Low voltage	Contactor (junction fusing)
Unintended reaction from button	Inverse reaction from button	Wrong phase sequence wiring	Feed power
		Incorrect signal wiring	Internal wiring
	No reaction after pressing button	Circuit wire break	Button switch
			Internal wiring
		Electric installation parts	Button switch
			Contactor
			Up/Down limit switch
			Contactor
			Brake
			Feed power
			Internal wiring
			Button switch
			Wire rope
			Load pulley, bare pulley
Noise of brake	Running (grating)	Drag	Gear
	Stop	Wear of friction plate	Bearing
Abnormal noise of rail curve (grating)		Obstruction of orbit/wheel	Brake
			Operation of trolley

Fault		Major Cause	Check Items
Does not move horizontally		Rail declining	Trolley movement
	Electric trolley /manual trolley	Inclined pull (wheel is lifting)	Trolley movement
	Electric trolley /manual trolley	Gear occlusion problem	Trolley movement
	Electric trolley /manual trolley	Brake fastening	Trolley movement
	Electric trolley	Electric faults	Trolley movement
Irregular movement and noise	Electric trolley /manual trolley	Rail & wheel interference	Trolley movement
		Side wheel lacks oil	
		Uneven wheel wear	
		Wheel deformation	
		Rail deformation, wear	
		Bearing wear	
		Brake wear	
Hook		Deformation	Hook
Wire rope		Wear or deformation	Wire rope
Electric shock upon touching machinery body or control switch		Equipment not properly grounded	Proper electric connection
Does not operate in non-load state	Brake inaudible	Supply power	Supply power voltage
		Operating circuit break-off, electric parts overheating	Cables
			Internal wiring
			Transformer
			Electrical relay
			Limit switch
		Push button switch	
	Braking interval too large or small.	Motor	
		Calibrate brake	
	Tripping as motor overheats	Thermal protector	
	Brake audible	Bearing burning out, driving component wear	Replace brake bearing
		Bearing	
Slow load operation	Voltage drop	Feed cable	
Low and high speed status not operating or working slow	Low voltage	Supply power	
	Voltage drop	Feed cable	
Movement does not correspond with switch button	Movement did not correspond with switch button	Motor wires connected	Motor
		Connection error	Internal wiring
			Push button switch
	Switch button did not work	Operating circuit break-off	Internal wiring
			Push button switch
	Electrical installation error	Limit switch	

Condition	Reason	Action	Cause	Correction
No operation	Abnormal supply voltage	Power supply	Improper power supply	Check power supply regularly

## Power Cable

Condition	Reason	Action	Cause	Correction
No operation	Wire break	Repair or change cable if broken	Strong force exerted	Firmly fix on cable support or other equipment
			(2 or more)	Use anti-vibration cable in movable part.
			Twisted, knotted	Straighten twists and knots
			Interference with other equipment	Use fixed cable and avoid outside interference
	Overheating	Check cables, exchange if overheating	Temperature rise due to off-capacity	Adopt the proper cable
			Binding cable used	Do not use binding cable
Starting slow or no operation	Off-capacity	Check cable diameter, replace cable if diameter is too small	Voltage drop	Adopt proper cable
Operation only in free load (single phase)	1 wire break or overheating	Refer to above break or overheating item		
Movement did not correspond with switch button (opposite)	Power line connection error	Replace wires	Wiring assembly error	Connect wire as per wiring diagram

## Motor

Condition	Reason	Action	Cause	Correction
No operation	Coil burning (above 2 phase)	Measure phase resistance value; change motor if value is infinite.	Excessive current caused by high or low voltage	Operate under rated voltage
			Excessive current caused by overload	Operate under rated voltage
			Beyond short-term rating and intermittent cycle rating	Short-term rating, intermittent cycle rating, operate under rated voltage
			Excessive current caused by brake	Avoid over-operation
	Lead wire break (above 2 phase)	Measure phase resistance value; change motor if value is infinite.	Lead wire broken in assembly	Change motor coil
			Vibration, drop	Avoid excessive bumping in usage
Operation only in free load (single phase state)	Coil burning (1 phase only)	Measure phase resistance value; change motor if value is infinite	Poor electric isolation	Ensure foreign matter does not enter motor
	Leading wire break (1 phase only)	Measure phase resistance value; change motor if value is infinite	Leading wire break in assembly	Change motor coil
			Vibration, drop	Avoid excessive bumping

## Brake

Condition	Reason	Action	Cause	Correction	
No operation	Braking coil burning	Measure brake phase resistance value; change brake if value is infinite.	Excessive current caused by high or low voltage	Operate under rated voltage	
				Avoid over-operation	
			Excessive current caused by overload	Operate under rated voltage	
				Confirm short-term rating, intermittent cycle rating, operate under rated voltage	
				Excessive current caused by operation in single phase state	Stop immediately if unable to lift load in single phase
	Friction plate beyond brake magnetism scope	Measure brake clearance, replace if space is over usage limit			Avoid over-operation
	Broken brake wire	Ensure wire is connected, replace if disconnected	Lead wire damaged during assembly		Replace coil brake
	Improper connection of brake wire terminal	Replace insert terminal when loose	Assembly error		Proper connection in assembly
	Rust	Replace brake if rust present		Exposure to water in storage	Ensure dry storage
			Condensation	Monitor usage environments	
Friction plate wear	Measure brake clearance, replace if space is over use limit			Avoid over-operation	

## Inside Wiring

Condition	Reason	Action	Cause	Correction
No operation	Break	Check cable, repair if wire break	Vibration, drop	Avoid excessive bumping in usage
			Leading wire damaged in assembly	Change motor coil
		Check connector, repair if wire break	Connector not properly set	Press by appropriate tool
	Wiring error	Refer to wiring diagram, ensure properly connected	Wiring error	Refer to wiring diagram, ensure properly connected
	Connector screws loose	Fastening	Improper fastening	Ensure effective fastening
	(overheating)		Vibration, drop	Avoid excessive bumping in usage
	Connector, insert terminal improper combination	Proper combination	Bad combination during assembly	Ensure combination is effective

## Transformer

Condition	Reason	Action	Cause	Correction
No operation (contractor)	Coil burning, break	Measure coil resistance value; Change transformer if value infinite	Excessive voltage	Operate under rated voltage
				Avoid over-operation
			Excessive current caused by contactor	Refer to contactor items
		Vibration, drop	Avoid excessive bumping in usage	
	Wire break	Check leading wire, repair or change transformer if wire	Vibration, drop	Avoid excessive bumping in usage

## Contactor & Electric Reply

Condition	Reason	Action	Cause	Correction
Non-stop activation	Junction welding burn out	Change contactor if continuous welding or burn out. For electric reply, visual inspection of junction		Do not over-operate
			Excessive voltage (Excessive current)	Operate under rated voltage
			Excessive current due to overload	Operation under rated voltage
No operation	Coil burning	Measure coil resistance value. Change coil if value infinite.		Avoid over-operation
			Excessive voltage	Operate under rated voltage
			Vibration due to low voltage (Starting current added continuous)	Operate under rated voltage
		Replace contactor if action is not smooth. For electric reply, visual inspection for part breakage	Vibration, drop	Avoid excessive bumping in usage



## Limit switch

Condition	Reason	Action	Cause	Correction
No operation (Contactor)	Contact fused	Operate limit switch. Check continuity of contactor, replace if result is negative	Limit switch overuse	Avoid overuse of switch
	Wire break	Inspect cable, change if wire breakage or replace limit switch	Vibration, drop	Avoid excessive bumping in usage
	Movable parts rusting	Check movable parts such as limit lever. Remove if rusty or replace if adhesive	Set in Up/Down limit for long time	Do not set in Up/Down limit
Motor did not stop upon reaching upper and lower limit	Contact welded	Operate limit switch. Check continuity of contactor, replace if does not open	Limit switch used frequently	Avoid overuse of limit switch
	Rusting of movable parts	Check movable parts such as limit lever. Remove if rusty or replace if adhesive	Infrequent usage; use in moist environments.	Regular inspection
	Wiring error	Reference wiring diagram. If limit switch cable is properly connected, it is inversely connected. Swap 2 wire power cords	Wiring error	Properly connect wire power cords as per wiring diagram

## Push button switch

Condition	Reason	Action	Cause	Correction
No operation (Contactor)	Emergency button is pressed	Turn button right to recover	Emergency button not reset	Read User Manual before usage
	Switch gear fault	Conduction contacts, replace switch if off	Vibration, drop	Avoid excessive bumping in usage
	Wiring break	Check if button cable is correctly connected to switch device. Repair if broken	Vibration, drop	Avoid excessive bumping in usage
	Terminal screw loose	Tighten screw	Vibration, drop	Avoid excessive bumping in usage
	Button cable wire break	Replace cable or button cable when wire break	Cable coating damaged	Avoid contact with other equipment during operation
Faulty installation			Install protection line firmly	
Action does not correspond with display	Wiring error	Reference wiring diagram. If limit switch cable is properly connected, it is inversely connected. Swap 2 wire power cords	Wiring error	Properly connect wire power cords as per wiring diagram
Operation continues upon button release	Faulty switch gear part	Replace switch if not smooth.	Vibration, drop	Avoid excessive bumping in usage

## Electric shock

Condition	Reason	Action	Cause	Correction
Electric shock upon touching machinery or control switch	Equipment not properly grounded	Measure earth resistance. If below 100Ω assemble ground wire	Improper ground wire connection	Firmly connect ground wire
			Ground wire bad connection	Assemble carefully to prevent loose screw
			Cable break	Do not apply excessive force on cable
	Dampness/ water	Clean, use once dry	Wet hands	Do not operate with wet hands

## Hook

Condition	Reason	Action	Cause	Correction
Hook mouth open	Hook deformation	Replace hook if deformation is beyond permitted range.	Overload	Operate under rated voltage
			Lifting (hook connected with grounded object)	Do not lift grounded objects.
			Load hanging on hook head; hook pull horizontal	Lifting load properly with hook
			Hanger suspension errors	Lifting angle must be controlled within 120 °
			Load size exceeds rated hook	Using proper hook
Hook twist			Wire rope wrapped around load	Do not wrap wire rope
Head hook improper rotating	Bearing rust, corrosion	Hand rotation; maintain or replace if experiencing difficulty rotating	Inadequate lubrication; corrosion	Apply grease lubricant regularly; prevent hook contamination of chemical agents
	Bearing damage		Dust	Prevent foreign matter from entering head

## Load pulley and empty pulley

Condition	Reason	Action	Cause	Correction
Irregular sound from springs (cracking sound)	Wear of pulley	Measure slot edge thickness and wire rope, replace if badly worn	Long-term operation with insufficient lubrication	Apply lubricating oil regularly
			Excessive operation	Avoid excessive operation
			Overload	Use under rated load
			Incline pull	Avoid incline pull

## Bearing

Condition	Reason	Action	Cause	Correction
Unable to lift loads	Breakage	Replace bearing	High temperature or high frequency	Avoid use at high temperatures or high frequency

## Trolley

Condition	Reason	Action	Cause	Correction
No drive due to wheel skid	Rail tilt	Confirm rail slope is within 1 °	Improper rail settings	Set up orbit correctly
No drive due to wheel skid	Apply oil above orbit wheel tread.	Ensure wheel is clean and unobstructed	Use in environment which outside material does not interfere with parts	Clean orbit regularly
Audible friction when travelling on curve track	Friction resistance between wheel and rail	Apply lubricating oil on track tread		
No drive on curve track	Interference of curve track and trolley	Confirm that orbit curve's radius is minimal bending radius	Curve track exceeding limit value	Avoid use on curve track exceeding limit value
Wheel raised and unable to be driven	Inclined pull (wheel raised)		Operation method	Correct use
Wheels stopped revolving	Faulty gear connection	Ensure clean space between wheel and gear	Interference from outside material	Check regularly
Abnormal sound	Improper adjustment circle	Confirm adjustment circle number and insert position	Insufficient confirmation	Install correctly
	Wear of wheel	Confirm wear degrees	Traveling surface has bump	Confirm regularly
	Deformation of wheel	Check wheel bending and surface damage	Excessive collision, traveling surface deformed	Replace and use correctly
	Aging of wheel bearings	Confirm irregular sound exists when wheel rotates	Reaching service life	Replace
	Deformation and wear of track	Confirm rail wear and deformation	Overload or reaching service life	Replace and use correctly

## Electric Trolley

Condition	Reason	Action	Cause	Correction
Wheels stopped revolving	Brake gelling	Open motor cover remove rust and dirt	Usage environment	Inspect regularly
	Electric fault	Refer to items of electric wire rope hoist		
Abnormal sound	Wear of edge guide wheel	Confirm wear degrees	Reaching service life	Confirm regularly
	Wear of friction slices	Confirm wear degrees of friction slices	Reaching service life	Confirm regularly

## Pairing transmitter and receiver

### Follow these instructions to pair the transmitter:

1. Disconnect the power supply from the unit.
2. Remove one battery from the transmitter.
3. While pressing the “up” and “stop” buttons replace the battery until the red LED on the transmitter flashes rapidly.
4. Re-connect the receiver to the power supply. The red LED on the transmitter will begin to flash slower. Press the “down” key on the transmitter. At this point, the transmitter and receiver are paired.

### If you need to change the code and channel on the transmitter, complete one of the following:

TO COPY TRANSMITTER CODE AND CHANNEL TO THE RECEIVER  
Press “UP” key to complete this operation.

TO COPY RECEIVER CODE AND CHANNEL TO THE TRANSMITTER  
Press “DOWN” key to complete this operation.

If the process has been successful, the green LED on the transmitter will flash once.

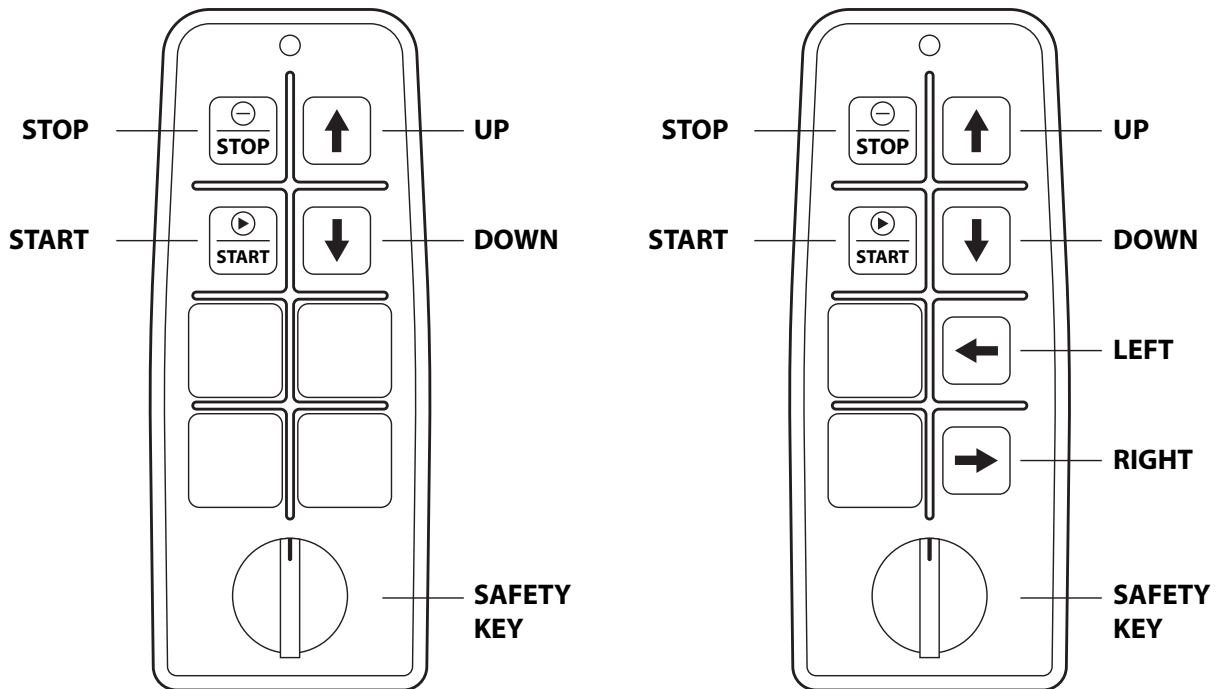



### **Prowinch LLC**

**[www.prowinch.com](http://www.prowinch.com)**

2545 NW 74th Ave Miami, Florida, 33122

United States

+1 (800) 971-8061

### **Equipos de Izaje Prowinch Chile Spa**

**[www.prowinch.cl](http://www.prowinch.cl)**

Parque Riesco 3407, Recoleta,

Región Metropolitana, Chile

+56-2-26218989

### **Fortis Alloy Mexico S.A. de C.V**

**[www.prowinch.mx](http://www.prowinch.mx)**

Fortis Alloy Mexico, S.A. de C.V. Vicente Guerrero No. 403

Col. San Miguel, Apodaca, Nuevo Leon,

Mexico C.P. 66649

+52 (81) 8244-1351

### **Prowinch Colombia SAS**

**[www.prowinch.co](http://www.prowinch.co)**

Cl. 163a #20-28, Bogotá, Colombia

+57 1 7034035

### **Provedora Industrial y Tecnica, S.A. de C.V.**

**[www.prointe.com.sv](http://www.prointe.com.sv)**

Av. Alberto Masferrer Sur, Col. Campestre No. 211

San Salvador, El Salvador

2264-1100

### **Representaciones Ivankovich RA S.A.**

**[ivankovich.co.cr](http://ivankovich.co.cr)**

100 mt. Este y 300 Mt. Sur de las Oficinas Centrales del

INS, Cartago, Costa Rica

(506) 2553-1415