



7.5 ton Electric Chain Hoist w/ Power Trolley Variable Speed 440~480V 3ø 50~60HZ

Características Esenciales

- 3 Años de Garantía, Servicio y Atención al Cliente en Chile

Especificaciones Técnicas

Capacidad de Carga	7.5 ton	Tipo de Cadena	G100 Nickel
Altura de Izaje Estandar (Customizable)	30 ft / 9 m	Dimensiones de la Cadena	11.2 mm
Velocidad /min	1.1~7 ft @60Hz mt @50Hz	Caidas de Cadena	3
Numero de Velocidades	Variable Speed	Longitud de cadena	90
Voltaje	3 Phase 440~480V 60Hz	Humedad	20%~90%
Potencia Total Watts	4000	Temperatura	-4 ~ 104° F / -20 ~ 40° C
Clase de Servicio	H4/M5/2m/Class D	Potencia del Trolley	750
Protección IEC Motor	IP55	Velocidad del Trolley /min	5.9~47.23 ft @60Hz 1.5~12 mt @50Hz
Control	Pendant Control IP66 and Optional Wireless	Cantidad de Velocidades	Variable
Voltaje del Control	24V	Normas	ASME HST-1 , ASME B30.16 , B30.17 , EN60204-37
Parada de Emergencia	Yes	Garantía	3 Year
Tipo Transmisión / Reductor	Spur gearbox		

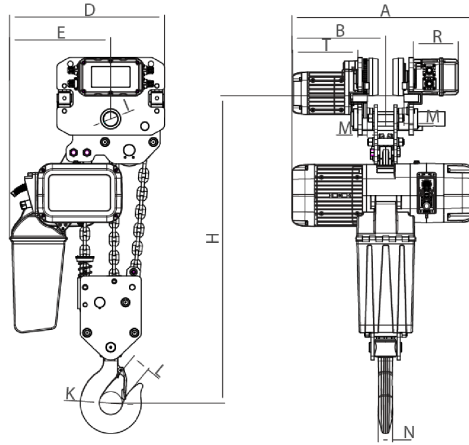

Rated load (t)	Type	Dimension (mm)												
		Minimum distance from the bottom of the track to the bottom hook: H	A	L	B	D	E	I	M	N	K	L	T	R
7	PWRXT7-03	1020	681	3500-5500	350	579	375	54	35	48	85	80	242	167

Peso & Dimensiones

H Altura Muerta	1170
W Ancho	576
A Altura Total	1020
J Boca Gancho	85
D Depth	681
Peso Total (sin cable o cadena)	130
Peso Total	869 lbs / 395 Kg

Detalles del Empaque

Paquete 1 Peso Neto	294.8 lbs / 134 Kg
Paquete 2 Peso Neto	345.4 lbs / 157 Kg
Paquete 1 Peso Bruto	495 lbs / 225 Kg
Paquete 2 Peso Bruto	374 lbs / 170 Kg
Paquete 1 Profundidad	30 in / 76.2 cm
Paquete 2 Profundidad	11 in / 27.94 cm
Paquete 1 Ancho	20 in / 50.8 cm
Paquete 2 Ancho	14 in / 35.56 cm
Paquete 1 Altura	31 in / 78.74 cm
Paquete 2 Altura	23 in / 58.42 cm

Referential Images / Imágenes Referenciales
Specifications may change without notice / las especificaciones pueden cambiar sin previo aviso