



## 5 ton Electric Chain Hoist w/ Power Trolley 2 Speed 575V 3 $\phi$ 1/2 50/60HZ

### Características Esenciales

- 3 Años de Garantía, Servicio y Atención al Cliente en Chile

## Especificaciones Técnicas

<b>Trolley Wheel Material</b>	No. 45 steel	<b>Numero de Velocidades</b>	2 Speed
<b>Paint Specifications</b>	Electrostatic Sprayed Plastic (ESP) Epoxy resins, Polyester Resins, Barium, Pigments	<b>Voltaje</b>	3 Phase 575v 50/60 Hz
<b>Trolley Beam Extension Kit</b>	up to 12"	<b>Potencia Total Watts</b>	3750
<b>Standards Certified</b>	CE	<b>Clase de Servicio</b>	H4/M5/2m/Class D
<b>Trolley Beam Range</b>	3.9" to 7"	<b>Protección IEC Motor</b>	IP55
<b>Trolley Minimum Turn Radius</b>	1.8	<b>Control</b>	Pendant Control IP66 and Optional Wireless
<b>Trolley Motor Brake Type and DC Voltage</b>	DC260V	<b>Voltaje del Control</b>	24V
<b>Trolley Motor Insulation Grade</b>	F	<b>Parada de Emergencia</b>	Yes
<b>Trolley Contactors Amps</b>	40A	<b>Hoist Contactor Brand</b>	Schneider
<b>Trolley Contactors Brand</b>	Schneider	<b>Tipo Transmisión / Reductor</b>	Spur gearbox
<b>Trolley Contactors Coil Voltage</b>	24 V	<b>Tipo de Cadena</b>	G100 Nikel
<b>Trolley Wheel Diameter</b>	139	<b>Dimensiones de la Cadena</b>	11.2 mm
<b>Optional Load Chain Brand &amp; Country of Origin</b>	FEC Japan	<b>Caidas de Cadena</b>	2
<b>Pendant Control Yes No</b>	Yes	<b>Longitud de cadena</b>	60
<b>Pendant Control Emergency Stop</b>	Yes	<b>Humedad</b>	20%~90%
<b>Overload Protection</b>	Overload Motor Clutch	<b>Temperatura</b>	-4 ~ 104° F / -20 ~ 40° C
<b>Brake SKU</b>	PWRX-2-20-PN.60.61	<b>Potencia del Trolley</b>	750
<b>Brake rectifiers-half-wave</b>	PWRX-BKTF-HW	<b>Velocidad del Trolley /min</b>	14.17~43.30 ft @60Hz 3.6~11 mt @50Hz
<b>Power Cord Length and Phase Order</b>	3 ft / Red L1, White L2 and Black L3, Green ground	<b>Cantidad de Velocidades</b>	2
<b>Recommended Hoist Protection Circuit Breaker AMPs and Type</b>	Type D 20A	<b>Rango de ancho de la Viga</b>	3.9" to 7"
<b>Capacidad de Carga</b>	5 ton	<b>Radio Minimo de Giro</b>	1.8
<b>Altura de Izaje Estandard (Customizable)</b>	30 ft / 9 m	<b>Normas</b>	ASME HST-1 , ASME B30.16 , B30.17 , EN60204-36
<b>Velocidad /min</b>	3.1/10.6 ft @60Hz 0.8/2.7 mt @50Hz	<b>Garantía</b>	3 Year

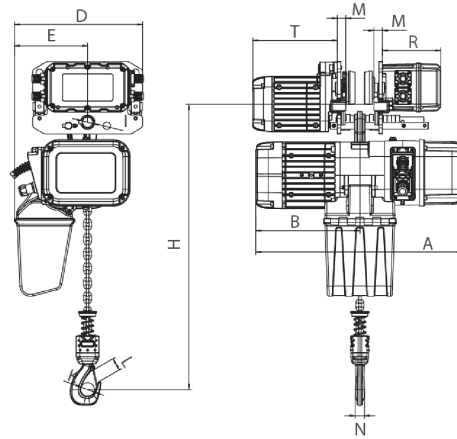

Rated load (t)	Type	Dimension (mm)												
		Minimum distance from the bottom of the track of the bottom to the bottom hook: H	A	L	B	D	E	I	M	N	K	L	T	R
1	PWRXT1-01	473	440	3500-5500	285	210	20	105	140					
2	PWRXT2-01	516	590		276	368	210	31	24	25	42	32	242	167
3	PWRXT3-01	600	681		350	422	264	36	28	35	52	42	242	167
5	PWRXT5-02	645	681		350	478	307	43	30	34	59	48	242	167

## Peso & Dimensiones

<b>H Altura Muerta</b>	810
<b>W Ancho</b>	500
<b>A Altura Total</b>	810
<b>J Boca Gancho</b>	60
<b>D Depth</b>	681
<b>Peso Total (sin cable o cadena)</b>	185
<b>Peso Total</b>	682 lbs / 310 Kg

## Detalles del Empaque

<b>Paquete 1 Peso Neto</b>	294.8 lbs / 134 Kg
<b>Paquete 2 Peso Neto</b>	172.7 lbs / 78 Kg
<b>Paquete 1 Peso Bruto</b>	495 lbs / 225 Kg
<b>Paquete 2 Peso Bruto</b>	187 lbs / 85 Kg
<b>Paquete 1 Profundidad</b>	30 in / 76.2 cm
<b>Paquete 2 Profundidad</b>	11 in / 27.94 cm
<b>Paquete 1 Ancho</b>	20 in / 50.8 cm
<b>Paquete 2 Ancho</b>	14 in / 35.56 cm
<b>Paquete 1 Altura</b>	31 in / 78.74 cm
<b>Paquete 2 Altura</b>	23 in / 58.42 cm

Referential Images / Imágenes Referenciales  
Specifications may change without notice / las especificaciones pueden cambiar sin previo aviso