



5 ton Electric Chain Hoist w/ Power Trolley 2 Speed 380V 3φ 1/2 50HZ

Características Esenciales

- 3 Años de Garantía, Servicio y Atención al Cliente en Chile

Especificaciones Técnicas

Trolley Wheel Material	No. 45 steel	Numero de Velocidades	2 Speed
Paint Specifications	Electrostatic Sprayed Plastic (ESP) Epoxy resins, Polyester Resins, Barium, Pigments	Voltaje	3 Phase 380V 50Hz
Trolley Beam Extension Kit	up to 12"	Potencia Total Watts	3750
Standards Certified	CE	Clase de Servicio	H4/M5/2m/Class D
Trolley Beam Range	3.9" to 7"	Protección IEC Motor	IP55
Trolley Minimum Turn Radius	1.8	Control	Pendant Control IP66 and Optional Wireless
Trolley Motor Brake Type and DC Voltage	DC170V	Voltaje del Control	24V
Trolley Motor Insulation Grade	F	Parada de Emergencia	Yes
Trolley Contactors Amps	40A	Hoist Contactor Brand	Schneider
Trolley Contactors Brand	Schneider	Tipo Transmisión / Reductor	Spur gearbox
Trolley Contactors Coil Voltage	24 V	Tipo de Cadena	G100 Nikel
Trolley Wheel Diameter	139	Dimensiones de la Cadena	11.2 mm
Optional Load Chain Brand & Country of Origin	FEC Japan	Caidas de Cadena	2
Pendant Control Yes No	Yes	Longitud de cadena	60
Pendant Control Emergency Stop	Yes	Humedad	20%~90%
Overload Protection	Overload Motor Clutch	Temperatura	-4 ~ 104° F / -20 ~ 40° C
Brake SKU	PWRX-2-20-PN.60.61	Potencia del Trolley	750
Brake rectifiers-half-wave	PWRX-BKTF-HW	Velocidad del Trolley /min	14.17~43.30 ft @60Hz 3.6~11 mt @50Hz
Power Cord Length and Phase Order	3 ft / Red L1, White L2 and Black L3, Green ground	Cantidad de Velocidades	2
Recommended Hoist Protection Circuit Breaker AMPs and Type	Type D 20A	Rango de ancho de la Viga	3.9" to 7"
Capacidad de Carga	5 ton	Radio Minimo de Giro	1.8
Altura de Izaje Estandard (Customizable)	30 ft / 9 m	Normas	ASME HST-1 , ASME B30.16 , B30.17 , EN60204-36
Velocidad /min	3.1/10.6 ft @60Hz 0.8/2.7 mt @50Hz	Garantía	3 Year

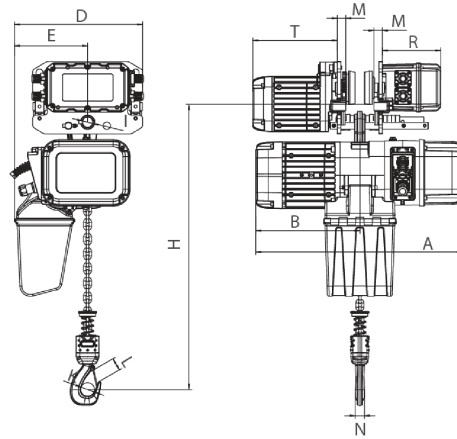

Rated load (t)	Type	Dimension (mm)													
		Minimum distance from the bottom of the track of the bottom to the bottom hook: H	A	L	B	D	E	I	M	N	K	L	T	R	
1	PWRXT1-01	473	440	3500-5500	285	210	20	105	140						
2	PWRXT2-01	516	590		276	368	210	31	24	25	42	32	242	167	
3	PWRXT3-01	600	681		350	422	264	36	28	35	52	42	242	167	
5	PWRXT5-02	645	681		350	478	307	43	30	34	59	48	242	167	

Peso & Dimensiones

H Altura Muerta	810
W Ancho	500
A Altura Total	810
J Boca Gancho	60
D Depth	681
Peso Total (sin cable o cadena)	185
Peso Total	682 lbs / 310 Kg

Detalles del Empaque

Paquete 1 Peso Neto	294.8 lbs / 134 Kg
Paquete 2 Peso Neto	172.7 lbs / 78 Kg
Paquete 1 Peso Bruto	495 lbs / 225 Kg
Paquete 2 Peso Bruto	187 lbs / 85 Kg
Paquete 1 Profundidad	30 in / 76.2 cm
Paquete 2 Profundidad	11 in / 27.94 cm
Paquete 1 Ancho	20 in / 50.8 cm
Paquete 2 Ancho	14 in / 35.56 cm
Paquete 1 Altura	31 in / 78.74 cm
Paquete 2 Altura	23 in / 58.42 cm

Referential Images / Imágenes Referenciales
Specifications may change without notice / las especificaciones pueden cambiar sin previo aviso