



5 ton Electric Chain Hoist w/ Power Trolley 2 Speed 208~240V / 440~480V 3ø 60HZ

Características Esenciales

- 3 Años de Garantía, Servicio y Atención al Cliente en Chile

Especificaciones Técnicas

Capacidad de Carga	5 ton	Humedad	20%~90%
Voltaje	3 Phase 208~240/440~480V 50/60Hz	Temperatura	-4 ~ 104° F / -20 ~ 40° C
Altura de Izaje Estandard (Customizable)	30 ft / 9 m	Tipo Transmisión / Reductor	Spur gearbox
Velocidad /min	3.1/ 10.6 ft @60Hz 0.8/2.7 mt @50Hz	Reducer Lubrication Type	Oil
Hoist Contactors Amps	25A	Paint Specifications	Electrostatic Sprayed Plastic (ESP) Epoxy resins, Polyester Resins, Barium, Pigments
Hoist Contactor Brand	Schneider	Normas	ASME HST-1 , ASME B30.16 , B30.17 , EN60204-36
Hoist Contactor Coil Voltage	24 V	Standards Certified	CE
Clase de Servicio	H4/M5/2m/Class D	Potencia del Trolley	750
IEC Hoist IP Protection	IP55	Cantidad de Velocidades	2
Protección IEC Motor	IP55	Velocidad del Trolley /min	14.17~43.30 ft @60Hz 3.6~11 mt @50Hz
Pendant Control Yes No	Yes	Trolley Motor Brake Type and DC Voltage	DC99V/DC207V
IEC Pendant Control Protection	IP66	Trolley Motor Insulation Grade	F
Pendant Control Emergency Stop	Yes	Trolley Contactors Amps	32A
Pendant Control total Length	27 ft	Trolley Contactors Brand	Schneider
Hoist Motor Power in KW	3	Trolley Contactors Coil Voltage	24 V
Hoist Motor Brake Type and DC Voltage	DC99V/DC207V	Trolley Wheel Diameter	139
Hoist Motor Insulation Grade	F	Trolley Wheel Material	No. 45 steel
Potencia Total Watts	3750	Trolley Minimum Turn Radius	1.8
Power Cord Length and Phase Order	3 ft / Black L1 , Red L2 and Blue L3 Green ground	Trolley Beam Range	3.9" to 7"
Recommended Hoist Protection Circuit Breaker AMPS and Type	Type D 25A at 220V and 20A at 460V	Trolley Beam Extension Kit	up to 12"
Optional Load Chain Brand & Country of Origin	FEC Japan	Overload Protection	Overload Motor Clutch
Tipo de Cadena	G100 Nikel	Hour Meter	Internal Working Hour Meter
Dimensiones de la Cadena	11.2 mm	Brake SKU	PWRX-2-20-PN.60.61
Caidas de Cadena	2	Brake rectifiers-half-wave	PWRX-BKTF-HW
Longitud de cadena	60	Brake rectifiers-full-wave	PWRX-BKTF-FW
Load Chain weight per foot [lbs]	1.83		

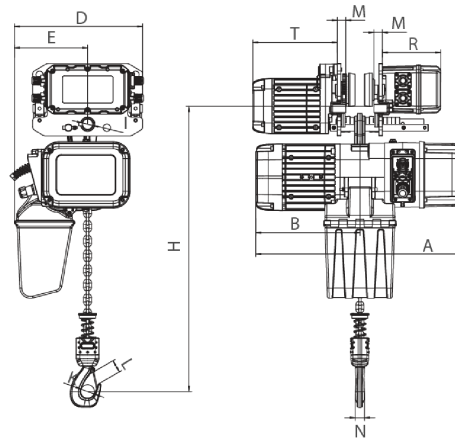

Rated load (t)	Type	Dimension (mm)													
		Minimum distance from the bottom of the track of the bottom to the bottom hook: H	A	L	B	D	E	I	M	N	K	L	T	R	
1	PWRXT1-01	473	440	3500-5500	285	210	20	105	140						
2	PWRXT2-01	516	590		276	368	210	31	24	25	42	32	242	167	
3	PWRXT3-01	600	681		350	422	264	36	28	35	52	42	242	167	
5	PWRXT5-02	645	681		350	478	307	43	30	34	59	48	242	167	

Peso & Dimensiones

A Altura Total	810
J Boca Gancho	60
W Ancho	500
H Altura Muerta	810
D Depth	681
1st Package Type	Wood Crate
Peso Total (sin cable o cadena)	185
2nd Package Type	Wood Crate
Peso Total	682 lbs / 310 Kg

Detalles del Empaque

Paquete 1 Altura	31 in / 78.74 cm
Paquete 2 Altura	23 in / 58.42 cm
Paquete 1 Ancho	20 in / 50.8 cm
Paquete 2 Ancho	14 in / 35.56 cm
Paquete 1 Profundidad	30 in / 76.2 cm
Paquete 2 Profundidad	11 in / 27.94 cm
Paquete 1 Peso Neto	294.8 lbs / 134 Kg
Paquete 2 Peso Neto	172.7 lbs / 78 Kg
Paquete 1 Peso Bruto	495 lbs / 225 Kg
Paquete 2 Peso Bruto	187 lbs / 85 Kg

Referential Images / Imágenes Referenciales
Specifications may change without notice / las especificaciones pueden cambiar sin previo aviso