



5 ton Electric Chain Hoist w/ Power Trolley 1 Speed 380V 3Ø 50HZ

Características Esenciales

- 3 Años de Garantía, Servicio y Atención al Cliente en Chile

Especificaciones Técnicas

Standards Certified	CE	Velocidad /min	10.63 ft @60Hz 2.70 mt @50Hz
Trolley Beam Range	3.9" to 7"	Numero de Velocidades	1 Speed
Trolley Minimum Turn Radius	1.8	Voltaje	3 Phase 380V 50Hz
Trolley Wheel Diameter	139	Potencia Total Watts	3750
Trolley Wheel Material	No. 45 steel	Clase de Servicio	H4/M5/2m/Class D
Trolley Contactors Coil Voltage	24 V	Protección IEC Motor	IP55
Trolley Contactors Brand	Schneider	Control	Pendant Control IP66 and Optional Wireless
Trolley Contactors Amps	40A	Voltaje del Control	24V
Trolley Motor Insulation Grade	F	Parada de Emergencia	Yes
Trolley Motor Brake Type and DC Voltage	DC170V	Hoist Contactor Brand	Schneider
Paint Specifications	Electrostatic Sprayed Plastic (ESP) Epoxy resins, Polyester Resins, Barium, Pigments	Tipo Transmisión / Reductor	Spur gearbox
Optional Load Chain Brand & Country of Origin	FEC Japan	Tipo de Cadena	G100 Nikel
Recommended Hoist Protection Circuit Breaker AMPs and Type	Type D 20A	Dimensiones de la Cadena	11.2 mm
Power Cord Length and Phase Order	3 ft / Red L1, White L2 and Black L3, Green ground	Caidas de Cadena	2
Brake rectifiers-half-wave	PWRX-BKTF-HW	Longitud de cadena	60
Brake SKU	PWRX-2-20-PN.60.61	Humedad	20%~90%
Overload Protection	Overload Motor Clutch	Temperatura	-4 ~ 104° F / -20 ~ 40° C
Pendant Control Yes No	Yes	Potencia del Trolley	750
Pendant Control Emergency Stop	Yes	Velocidad del Trolley /min	43.30 ft @60Hz 11 mt @50Hz
Trolley Beam Extension Kit	up to 12"	Cantidad de Velocidades	1
Capacidad de Carga	5 ton	Normas	ASME HST-1 , ASME B30.16 , B30.17 , EN60204-36
Altura de Izaje Estandar (Customizable)	30 ft / 9 m	Garantía	3 Year

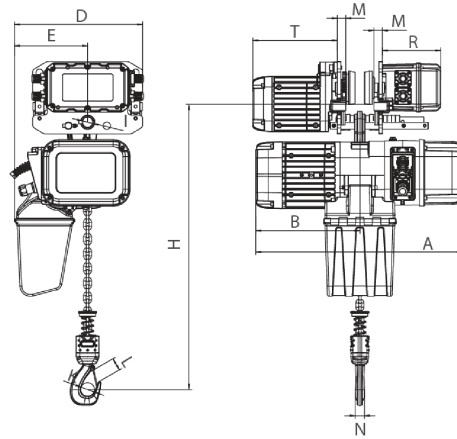

Rated load (t)	Type	Dimension (mm)													
		Minimum distance from the bottom of the track of the bottom to the bottom hook: H	A	L	B	D	E	I	M	N	K	L	T	R	
1	PWRXT1-01	473	440	3500-5500	285	210	20	105	140						
2	PWRXT2-01	516	590		276	368	210	31	24	25	42	32	242	167	
3	PWRXT3-01	600	681		350	422	264	36	28	35	52	42	242	167	
5	PWRXT5-02	645	681		350	478	307	43	30	34	59	48	242	167	

Peso & Dimensiones

H Altura Muerta	810
W Ancho	420
A Altura Total	675
J Boca Gancho	60
D Depth	695
Peso Total (sin cable o cadena)	185
Peso Total	616 lbs / 280 Kg

Detalles del Empaque

Paquete 1 Peso Neto	294.8 lbs / 134 Kg
Paquete 2 Peso Neto	111.1 lbs / 50 Kg
Paquete 1 Peso Bruto	495 lbs / 225 Kg
Paquete 2 Peso Bruto	121 lbs / 55 Kg
Paquete 1 Profundidad	30 in / 76.2 cm
Paquete 2 Profundidad	11 in / 27.94 cm
Paquete 1 Ancho	20 in / 50.8 cm
Paquete 2 Ancho	14 in / 35.56 cm
Paquete 1 Altura	31 in / 78.74 cm
Paquete 2 Altura	23 in / 58.42 cm

Referential Images / Imágenes Referenciales
Specifications may change without notice / las especificaciones pueden cambiar sin previo aviso