



3 ton Electric Chain Hoist w/ Power Trolley Variable Speed 380V 3Ø 50~60HZ

Características Esenciales

- 3 Años de Garantía, Servicio y Atención al Cliente en Chile

Especificaciones Técnicas

Capacidad de Carga	3 ton	Tipo de Cadena	G100 Nickel
Altura de Izaje Estandar (Customizable)	30 ft / 9 m	Dimensiones de la Cadena	11.2 mm
Velocidad /min	ft @60Hz 0.7~5.4 mt @50Hz	Caidas de Cadena	1
Numero de Velocidades	Variable Speed	Longitud de cadena	30 ft (9 m)
Voltaje	3 Phase 380V 50Hz	Humedad	20%~90%
Potencia Total Watts	4000	Temperatura	-4 ~ 104° F / -20 ~ 40° C
Clase de Servicio	H4/M5/2m/Class D	Potencia del Trolley	500
Protección IEC Motor	IP55	Velocidad del Trolley /min	5.9~47.23 ft @60Hz 1.5~12 mt @50Hz
Control	Pendant Control IP66 and Optional Wireless	Cantidad de Velocidades	Variable
Voltaje del Control	24V	Normas	ASME HST-1 , ASME B30.16 , B30.17 , EN60204-35
Parada de Emergencia	Yes	Garantía	3 Year
Tipo Transmisión / Reductor	Spur gearbox		

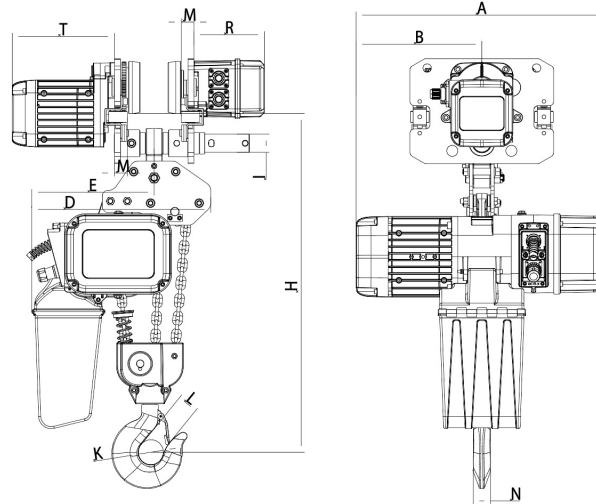

H	A	B	D	E	I	M	N	K	L	T	R
645	590	276	425	290	43	30	34	59	48	242	.167

Peso & Dimensiones

H Altura Muerta	645
W Ancho	350
A Altura Total	645
J Boca Gancho	59
D Depth	681
Peso Total (sin cable o cadena)	130
Peso Total	451 lbs / 205 Kg

Detalles del Empaque

Paquete 1 Peso Neto	184.8 lbs / 84 Kg
Paquete 2 Peso Neto	111.1 lbs / 50 Kg
Paquete 1 Peso Bruto	330 lbs / 150 Kg
Paquete 2 Peso Bruto	121 lbs / 55 Kg
Paquete 1 Profundidad	30 in / 76.2 cm
Paquete 2 Profundidad	11 in / 27.94 cm
Paquete 1 Ancho	20 in / 50.8 cm
Paquete 2 Ancho	14 in / 35.56 cm
Paquete 1 Altura	31 in / 78.74 cm
Paquete 2 Altura	23 in / 58.42 cm

Referential Images / Imágenes Referenciales
Specifications may change without notice / las especificaciones pueden cambiar sin previo aviso