



3 ton Electric Chain Hoist w/ Power Trolley Variable Speed 220V 1Ø 50~60HZ

Características Esenciales

- 3 Años de Garantía, Servicio y Atención al Cliente en Chile

Especificaciones Técnicas

Optional Load Chain Brand & Country of Origin	FEC Japan	Brake rectifiers-half-wave	PWRX-BKTF-HW
Standards Certified	CE	Capacidad de Carga	3 ton
Recommended Hoist Protection Circuit Breaker AMPs and Type	Type D 20A	Altura de Izaje Estandar (Customizable)	30 ft / 9 m
Power Cord Length and Phase Order	3 ft / Black L1, White, Green ground	Velocidad /min	ft @60Hz 0.7~5.4 mt @50Hz
Pendant Control Yes No	Yes	Numero de Velocidades	Variable Speed
Pendant Control Emergency Stop	Yes	Voltaje	1 Phase 220~240V 50/60Hz
Paint Specifications	Electrostatic Sprayed Plastic (ESP) Epoxy resins, Polyester Resins, Barium, Pigments	Potencia Total Watts	4000
Overload Protection	Overload Motor Clutch	Clase de Servicio	H4/M5/2m/Class D
Trolley Beam Extension Kit	up to 12"	Protección IEC Motor	IP55
VFD Model	Z230	Tipo Transmisión / Reductor	Spur gearbox
Trolley Wheel Material	No. 45 steel	Tipo de Cadena	G100 Nikel
Trolley Wheel Diameter	124	Dimensiones de la Cadena	11.2 mm
Trolley VFD Power in KW	2.5kW	Caidas de Cadena	1
Trolley VFD Model	Z230	Longitud de cadena	30
Trolley VFD Brand	Huayuan	Humedad	20%~90%
Trolley Motor Insulation Grade	F	Temperatura	-4 ~ 104° F / -20 ~ 40° C
Brake SKU	PWRX-2-20-PN.60.61	Potencia del Trolley	500
Trolley Motor Brake Type and DC Voltage	DC170V	Velocidad del Trolley /min	5.9~47.23 ft @60Hz 1.5~12 mt @50Hz
Trolley Minimum Turn Radius	1.6	Cantidad de Velocidades	Variable
Trolley Beam Range	3.9" to 7"	Normas	ASME HST-1 , ASME B30.16 , B30.17 , EN60204-35
Brake Resistor Kw	1Kw	Garantía	3 Year

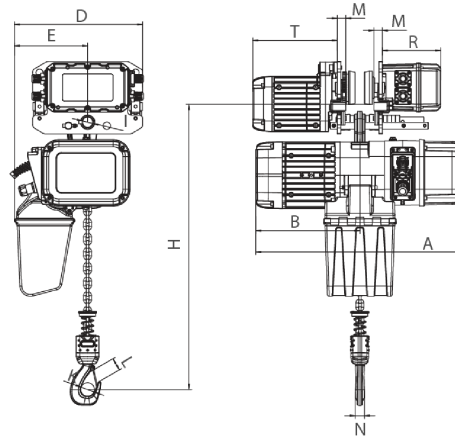

Rated load (t)	Type	Dimension (mm)													
		Minimum distance from the bottom of the track to the bottom hook: H	A	L	B	D	E	I	M	N	K	L	T	R	
1	PWRXT1-01	473	440	3500-5500	285	210	20	105	140						
2	PWRXT2-01	516	590		276	368	210	31	24	25	42	32	242	167	
3	PWRXT3-01	600	681		350	422	264	36	28	35	52	42	242	167	
5	PWRXT5-02	645	681		350	478	307	43	30	34	59	48	242	167	

Peso & Dimensiones

H Altura Muerta	645
W Ancho	350
A Altura Total	645
J Boca Gancho	59
D Depth	681
Peso Total (sin cable o cadena)	130
Peso Total	560 lbs / 255 Kg

Detalles del Empaque

Paquete 1 Peso Neto	184.8 lbs / 84 Kg
Paquete 1 Ancho	20 in / 50.8 cm
Paquete 1 Peso Bruto	560 lbs / 254 Kg
Paquete 1 Altura	44 in / 111.76 cm
Paquete 1 Profundidad	30 in / 76.2 cm

Referential Images / Imágenes Referenciales
Specifications may change without notice / las especificaciones pueden cambiar sin previo aviso