



3 ton Electric Chain Hoist w/ Power Trolley Variable Speed 110V 1Ø 60HZ

Características Esenciales

- 3 Años de Garantía, Servicio y Atención al Cliente en Chile

Especificaciones Técnicas

Capacidad de Carga	3 ton	Longitud de cadena	30
Voltaje	1 Phase 110~120V 60Hz	Load Chain weight per foot [lbs]	1.83
Altura de Izaje Estandar (Customizable)	30 ft / 9 m	Humedad	20%~90%
Velocidad /min	ft @60Hz 0.7~5.4 mt @50Hz	Temperatura	-4 ~ 104° F / -20 ~ 40° C
Numero de Velocidades	Variable Speed	Tipo Transmisión / Reductor	Spur gearbox
Hoist VFD Power	4kW	Reducer Lubrication Type	Oil
Hoist VFD Brand	HUAYUAN	Paint Specifications	Electrostatic Sprayed Plastic (ESP) Epoxy resins, Polyester Resins, Barium, Pigments
VFD Model	Z230	Normas	ASME HST-1 , ASME B30.16 , B30.17 , EN60204-35
Brake Resistor Kw	1Kw	Standards Certified	CE
Clase de Servicio	H4/M5/2m/Class D	Potencia del Trolley	500
IEC Hoist IP Protection	IP55	Cantidad de Velocidades	Variable
Protección IEC Motor	IP55	Velocidad del Trolley /min	5.9~47.23 ft @60Hz 1.5~12 mt @50Hz
Pendant Control Yes No	Yes	Trolley Motor Brake Type and DC Voltage	DC170V
IEC Pendant Control Protection	IP66	Trolley Motor Insulation Grade	F
Pendant Control Emergency Stop	Yes	Trolley VFD Power in KW	2.5kW
Pendant Control total Length	27 ft	Trolley VFD Brand	Huayuan
Hoist Motor Power in KW	3	Trolley VFD Model	Z230
Hoist Motor Brake Type and DC Voltage	DC170V	Trolley Wheel Diameter	124
Hoist Motor Insulation Grade	F	Trolley Wheel Material	No. 45 steel
Potencia Total Watts	4000	Trolley Minimum Turn Radius	1.6
Power Cord Length and Phase Order	3 ft / Black L1, White, Green ground	Trolley Beam Range	3.9" to 7"
Recommended Hoist Protection Circuit Breaker AMPs and Type	Type D 20A	Trolley Beam Extension Kit	up to 12"
Optional Load Chain Brand & Country of Origin	FEC Japan	Overload Protection	Overload Motor Clutch
Tipo de Cadena	G100 Nikel	Hour Meter	Internal Working Hour Meter
Dimensiones de la Cadena	11.2 mm	Brake SKU	PWRX-2-20-PN.60.61
Caidas de Cadena	1	Brake rectifiers-half-wave	PWRX-BKTF-HW

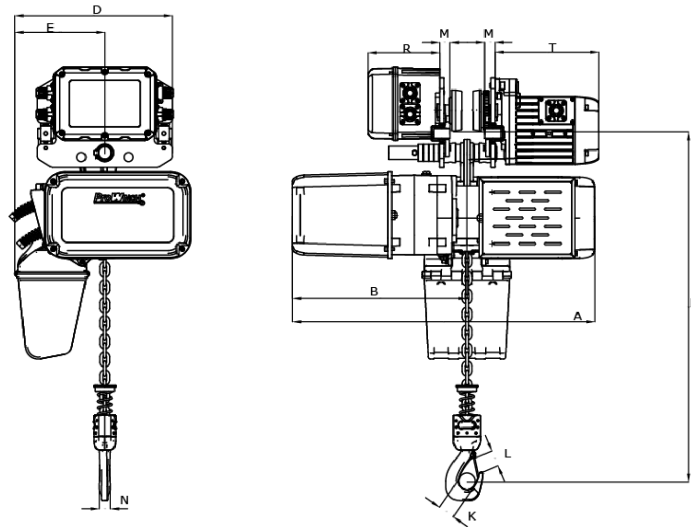

Rated load (t)	Type	Minimum distance from the bottom of the track to the bottom hook: H	Dimension (mm)											
			A	L	B	D	E	I	M	N	K	L	T	R
1	PWRXT1-VS-110V	516	704.5	3500-5500	406.5	368	210	31	24	25	42	32	242	167
2-3	PWRXT2-3-VS-110V	640	780		348	463	263	45	20	35	52	42	242	167

Peso & Dimensiones

A Altura Total	645
J Boca Gancho	59
W Ancho	350
H Altura Muerta	645
D Depth	681
1st Package Type	Wood Crate
Peso Total (sin cable o cadena)	130
2nd Package Type	Wood Crate
Peso Total	451 lbs / 205 Kg

Detalles del Empaque

Paquete 1 Altura	31 in / 78.74 cm
Paquete 2 Altura	23 in / 58.42 cm
Paquete 1 Ancho	20 in / 50.8 cm
Paquete 2 Ancho	14 in / 35.56 cm
Paquete 1 Profundidad	30 in / 76.2 cm
Paquete 2 Profundidad	11 in / 27.94 cm
Paquete 1 Peso Neto	184.8 lbs / 84 Kg
Paquete 2 Peso Neto	111.1 lbs / 50 Kg
Paquete 1 Peso Bruto	330 lbs / 150 Kg
Paquete 2 Peso Bruto	121 lbs / 55 Kg

Referential Images / Imágenes Referenciales
Specifications may change without notice / las especificaciones pueden cambiar sin previo aviso