



## 3 ton Electric Chain Hoist w/ Power Trolley Variable Speed 440~480V 3Ø 50~60HZ

### Características Esenciales

- 3 Años de Garantía, Servicio y Atención al Cliente en Chile

### Especificaciones Técnicas

<b>Capacidad de Carga</b>	3 ton	<b>Tipo de Cadena</b>	G100 Nickel
<b>Altura de Izaje Estandar (Customizable)</b>	30 ft / 9 m	<b>Dimensiones de la Cadena</b>	11.2 mm
<b>Velocidad /min</b>	2.7~21.2 ft @60Hz mt @50Hz	<b>Caidas de Cadena</b>	1
<b>Numero de Velocidades</b>	Variable Speed	<b>Longitud de cadena</b>	30
<b>Voltaje</b>	3 Phase 440~480V 60Hz	<b>Humedad</b>	20%~90%
<b>Potencia Total Watts</b>	4000	<b>Temperatura</b>	-4 ~ 104° F / -20 ~ 40° C
<b>Clase de Servicio</b>	H4/M5/2m/Class D	<b>Potencia del Trolley</b>	500
<b>Protección IEC Motor</b>	IP55	<b>Velocidad del Trolley /min</b>	5.9~47.23 ft @60Hz 1.5~12 mt @50Hz
<b>Control</b>	Pendant Control IP66 and Optional Wireless	<b>Cantidad de Velocidades</b>	Variable
<b>Voltaje del Control</b>	24V	<b>Normas</b>	ASME HST-1 , ASME B30.16 , B30.17 , EN60204-35
<b>Parada de Emergencia</b>	Yes	<b>Garantía</b>	3 Year
<b>Tipo Transmisión / Reductor</b>	Spur gearbox		

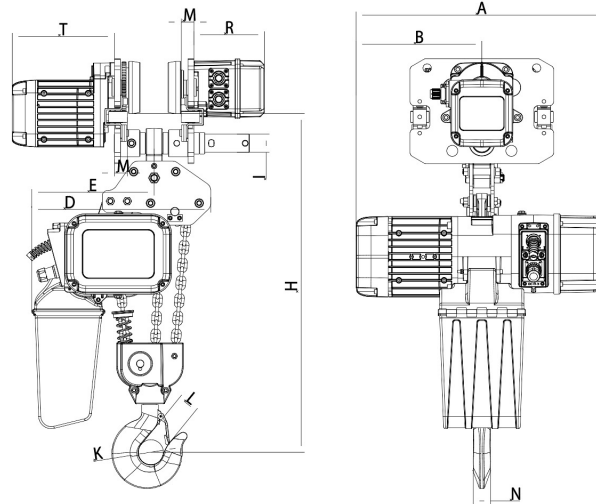

H	A	B	D	E	I	M	N	K	L	T	R
645	590	276	425	290	43	30	34	59	48	242	.167

## Peso & Dimensiones

<b>H Altura Muerta</b>	645
<b>W Ancho</b>	350
<b>A Altura Total</b>	645
<b>J Boca Gancho</b>	59
<b>D Depth</b>	681
<b>Peso Total (sin cable o cadena)</b>	130
<b>Peso Total</b>	451 lbs / 205 Kg

## Detalles del Empaque

<b>Paquete 1 Peso Neto</b>	184.8 lbs / 84 Kg
<b>Paquete 2 Peso Neto</b>	111.1 lbs / 50 Kg
<b>Paquete 1 Peso Bruto</b>	330 lbs / 150 Kg
<b>Paquete 2 Peso Bruto</b>	121 lbs / 55 Kg
<b>Paquete 1 Profundidad</b>	30 in / 76.2 cm
<b>Paquete 2 Profundidad</b>	11 in / 27.94 cm
<b>Paquete 1 Ancho</b>	20 in / 50.8 cm
<b>Paquete 2 Ancho</b>	14 in / 35.56 cm
<b>Paquete 1 Altura</b>	31 in / 78.74 cm
<b>Paquete 2 Altura</b>	23 in / 58.42 cm

Referential Images / Imágenes Referenciales  
Specifications may change without notice / las especificaciones pueden cambiar sin previo aviso