



3 ton Electric Chain Hoist w/ Power Trolley 2 Speed 575V 3 ϕ 1/2 50/60HZ

Características Esenciales

- 3 Años de Garantía, Servicio y Atención al Cliente en Chile

Especificaciones Técnicas

Capacidad de Carga	3 ton	Load Chain weight per foot [lbs]	1.83
Voltaje	3 Phase 575v 50/60hz	Humedad	20%~90%
Altura de Izaje Estandar (Customizable)	30 ft / 9 m	Temperatura	-4 ~ 104° F / -20 ~ 40° C
Velocidad /min	11.1/21.2 ft @60Hz 1.7/5.4 mt @50Hz	Tipo Transmisión / Reductor	Spur gearbox
Numero de Velocidades	2 Speed	Reducer Lubrication Type	Oil
Hoist Contactors Amps	25A	Paint Specifications	Electrostatic Sprayed Plastic (ESP) Epoxy resins, Polyester Resins, Barium, Pigments
Hoist Contactor Brand	Schneider	Normas	ASME HST-1 , ASME B30.16 , B30.17 , EN60204-35
Hoist Contactor Coil Voltage	24 V	Standards Certified	CE
Clase de Servicio	H4/M5/2m/Class D	Potencia del Trolley	500
IEC Hoist IP Protection	IP55	Cantidad de Velocidades	2
Protección IEC Motor	IP55	Velocidad del Trolley /min	14.17~43.30 ft @60Hz 3.6~11 mt @50Hz
Pendant Control Yes No	Yes	Trolley Motor Brake Type and DC Voltage	DC260V
IEC Pendant Control Protection	IP66	Trolley Motor Insulation Grade	F
Pendant Control Emergency Stop	Yes	Trolley Contactors Amps	32A
Pendant Control total Length	27 ft	Trolley Contactors Brand	Schneider
Hoist Motor Power in KW	3	Trolley Contactors Coil Voltage	24 V
Hoist Motor Brake Type and DC Voltage	DC260V	Trolley Wheel Diameter	124
Hoist Motor Insulation Grade	F	Trolley Wheel Material	No. 45 steel
Potencia Total Watts	3500	Trolley Minimum Turn Radius	1.6
Power Cord Length and Phase Order	3 ft / Red L1, White L2 and Black L3, Green ground	Trolley Beam Range	3.9" to 7"
Recommended Hoist Protection Circuit Breaker AMPS and Type	Type D 20A	Trolley Beam Extension Kit	up to 12"
Optional Load Chain Brand & Country of Origin	FEC Japan	Overload Protection	Overload Motor Clutch
Tipo de Cadena	G100 Nikel	Hour Meter	Internal Working Hour Meter
Dimensiones de la Cadena	11.2 mm	Brake SKU	PWRX-2-20-PN.60.61
Caidas de Cadena	1	Brake rectifiers-half-wave	PWRX-BKTF-HW
Longitud de cadena	30		

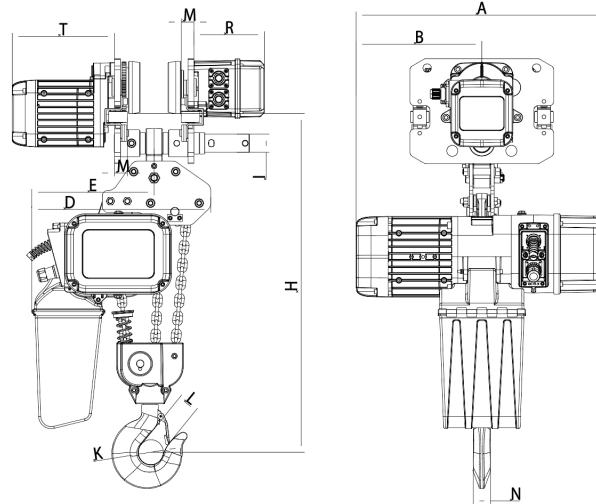

H	A	B	D	E	I	M	N	K	L	T	R
762	590	276	425	290	43	30	34	59	48	242	.167

Peso & Dimensiones

A Altura Total	645
J Boca Gancho	59
W Ancho	350
H Altura Muerta	645
D Depth	681
1st Package Type	Wood Crate
Peso Total (sin cable o cadena)	130
2nd Package Type	Wood Crate
Peso Total	451 lbs / 205 Kg

Detalles del Empaque

Paquete 1 Altura	31 in / 78.74 cm
Paquete 2 Altura	23 in / 58.42 cm
Paquete 1 Ancho	20 in / 50.8 cm
Paquete 2 Ancho	14 in / 35.56 cm
Paquete 1 Profundidad	30 in / 76.2 cm
Paquete 2 Profundidad	11 in / 27.94 cm
Paquete 1 Peso Neto	184.8 lbs / 84 Kg
Paquete 2 Peso Neto	111.1 lbs / 50 Kg
Paquete 1 Peso Bruto	330 lbs / 150 Kg
Paquete 2 Peso Bruto	121 lbs / 55 Kg

Referential Images / Imágenes Referenciales
Specifications may change without notice / las especificaciones pueden cambiar sin previo aviso