



3 ton Electric Chain Hoist w/ Power Trolley 2 Speed 208~240V / 440~480V 3ph 60HZ

Características Esenciales

- 3 Años de Garantía, Servicio y Atención al Cliente en Chile

3 ton Electric Chain Hoist w/ Power Trolley 2 Speed 208~240V / 440~480V 3ø 60HZ 30ft G100 Nickel Duty H4/M5

Especificaciones Técnicas

Capacidad de Carga	3 ton	Dimensiones de la Cadena	11.2 mm
Altura de Izaje Estandar (Customizable)	30 ft / 9 m	Caidas de Cadena	1
Velocidad /min	11.1/ 21.2 ft @60Hz 1.7/5.4 mt @50Hz	Longitud de cadena	30
Voltaje	3 Phase 208~240/440~480V 50/60Hz	Humedad	20%~90%
Potencia Total Watts	3500	Temperatura	-4 ~ 104° F / -20 ~ 40° C
Clase de Servicio	H4/M5/2m/Class D	Potencia del Trolley	500
Protección IEC Motor	IP55	Velocidad del Trolley /min	14.17~43.30 ft @60Hz 3.6~11 mt @50Hz
Control	Pendant Control IP66 and Optional Wireless	Cantidad de Velocidades	2
Voltaje del Control	24V	Rango de ancho de la Viga	3.9" to 7"
Parada de Emergencia	Yes	Radio Minimo de Giro	1.6
Tipo Transmisión / Reductor	Spur gearbox	Normas	ASME HST-1 , ASME B30.16 , B30.17 , EN60204-35
Tipo de Cadena	G100 Nickel	Garantía	3 Year

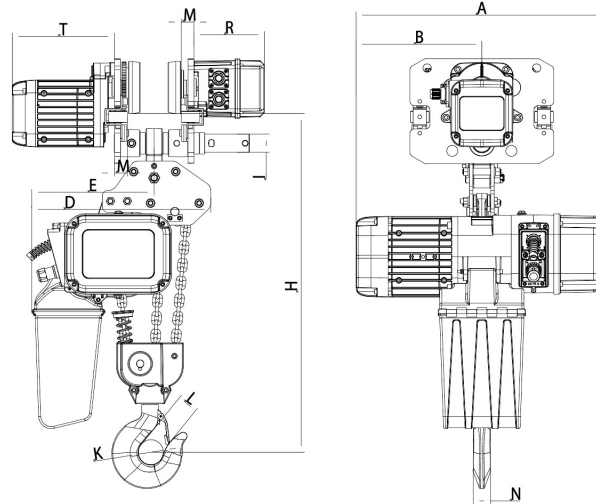

H	A	B	D	E	I	M	N	K	L	T	R
645	590	276	425	290	43	30	34	59	48	242	.167

Peso & Dimensiones

H Altura Muerta	645
W Ancho	350
A Altura Total	645
J Boca Gancho	59
D Depth	681
Peso Total (sin cable o cadena)	130
Peso Total	517 lbs / 235 Kg

Detalles del Empaque

Paquete 1 Peso Neto	184.8 lbs / 84 Kg
Paquete 2 Peso Neto	172.7 lbs / 78 Kg
Paquete 1 Peso Bruto	330 lbs / 150 Kg
Paquete 2 Peso Bruto	187 lbs / 85 Kg
Paquete 1 Profundidad	30 in / 76.2 cm
Paquete 2 Profundidad	11 in / 27.94 cm
Paquete 1 Ancho	20 in / 50.8 cm
Paquete 2 Ancho	14 in / 35.56 cm
Paquete 1 Altura	31 in / 78.74 cm
Paquete 2 Altura	23 in / 58.42 cm

Referential Images / Imágenes Referenciales
Specifications may change without notice / las especificaciones pueden cambiar sin previo aviso