



## **3 ton Electric Chain Hoist w/ Power Trolley 1 Speed 208~240V / 440~480V 3ph 60HZ**

### **Características Esenciales**

- 3 Años de Garantía, Servicio y Atención al Cliente en Chile

## Especificaciones Técnicas

|   |  |                                    |  |
|---|--|------------------------------------|--|
| <b>Trolley Motor Brake Type and DC Voltage</b>                    | DC99V/DC207V   | <b>Velocidad /min</b>              | 21.23 ft @60Hz<br>5.40 mt @50Hz                |
| <b>Trolley Beam Extension Kit</b>                                 | up to 12"  | <b>Numero de Velocidades</b>       | 1 Speed  |
| <b>Trolley Beam Range</b>   | 3.9" to 7"   | <b>Voltaje</b>                     | 3 Phase 208~240/440~480V 50/60Hz               |
| <b>Trolley Minimum Turn Radius</b>                                | 1.6  | <b>Potencia Total Watts</b>        | 4000   |
| <b>Trolley Wheel Material</b>                                     | No. 45 steel   | <b>Clase de Servicio</b>           | H4/M5/2m/Class D                               |
| <b>Trolley Wheel Diameter</b>                                     | 124  | <b>Protección IEC Motor</b>        | IP55   |
| <b>Trolley Contactors Coil Voltage</b>                            | 24 V   | <b>Control</b>                     | Pendant Control IP66 and Optional Wireless     |
| <b>Trolley Contactors Brand</b>                                   | Schneider  | <b>Voltaje del Control</b>         | 24V  |
| <b>Trolley Contactors Amps</b>                                    | 32A  | <b>Parada de Emergencia</b>        | Yes  |
| <b>Trolley Motor Insulation Grade</b>                             | F  | <b>Hoist Contactor Brand</b>       | Schneider                                      |
| <b>Brake rectifiers-half-wave</b>                                 | PWRX-BKTF-HW   | <b>Tipo Transmisión / Reductor</b> | Spur gearbox                                   |
| <b>Standards Certified</b>  | CE   | <b>Tipo de Cadena</b>              | G100 Nikel                                     |
| <b>Paint Specifications</b>                                       | Electrostatic Sprayed Plastic (ESP)<br>Epoxy resins, Polyester Resins,<br>Barium, Pigments | <b>Dimensiones de la Cadena</b>    | 11.2 mm  |
| <b>Optional Load Chain Brand &amp; Country of Origin</b>          | FEC Japan  | <b>Caidas de Cadena</b>            | 1  |
| <b>Recommended Hoist Protection Circuit Breaker AMPs and Type</b> | Type D 25A at 220V and 20A at 460V   | <b>Longitud de cadena</b>          | 30   |
| <b>Power Cord Length and Phase Order</b>                          | 3 ft / Black L1 , Red L2 and Blue L3<br>Green ground                                       | <b>Humedad</b>                     | 20%~90%  |
| <b>Overload Protection</b>  | Overload Motor Clutch  | <b>Temperatura</b>                 | -4 ~ 104° F / -20 ~ 40° C                      |
| <b>Pendant Control Emergency Stop</b>                             | Yes  | <b>Potencia del Trolley</b>        | 500  |
| <b>Pendant Control Yes No</b>                                     | Yes  | <b>Velocidad del Trolley /min</b>  | 43.30 ft @60Hz<br>11 mt @50Hz                  |
| <b>Brake SKU</b>  | PWRX-2-20-PN.60.61   | <b>Cantidad de Velocidades</b>     | 1  |
| <b>Capacidad de Carga</b>   | 3 ton  | <b>Normas</b>                      | ASME HST-1 , ASME B30.16 , B30.17 , EN60204-35 |
| <b>Altura de Izaje Estandard (Customizable)</b>                   | 30 ft / 9 m  | <b>Garantía</b>                    | 3 Year   |

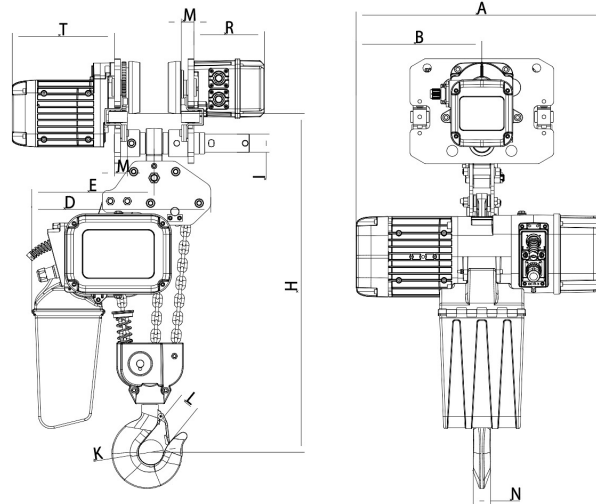

| H   | A   | B   | D   | E   | I  | M  | N  | K  | L  | T   | R    |
|-----|-----|-----|-----|-----|----|----|----|----|----|-----|------|
| 645 | 590 | 276 | 425 | 290 | 43 | 30 | 34 | 59 | 48 | 242 | .167 |

## Peso & Dimensiones

|  |                  |                              |                   |
|--|------------------|------------------------------|-------------------|
| <b>H Altura Muerta</b>                 | 645              | <b>Paquete 1 Peso Neto</b>   | 184.8 lbs / 84 Kg |
| <b>W Ancho</b>                         | 420              | <b>Paquete 1 Ancho</b>       | 20 in / 50.8 cm   |
| <b>A Altura Total</b>                  | 560              | <b>Paquete 1 Peso Bruto</b>  | 410 lbs / 186 Kg  |
| <b>J Boca Gancho</b>                   | 59               | <b>Paquete 1 Altura</b>      | 44 in / 111.76 cm |
| <b>D Depth</b>                         | 695              | <b>Paquete 1 Profundidad</b> | 31 in / 78.74 cm  |
| <b>Peso Total (sin cable o cadena)</b> | 130              |                              |                   |
| <b>Peso Total</b>                      | 410 lbs / 187 Kg |                              |                   |

## Detalles del Empaque

Referential Images / Imágenes Referenciales

Specifications may change without notice / las especificaciones pueden cambiar sin previo aviso