



20 ton Electric Chain Hoist w/ Power Trolley Variable Speed Trolley 380V 3ø, 50HZ 40ft G100 Nickel Duty H4/M5

Características Esenciales

- 3 Años de Garantía, Servicio y Atención al Cliente en Chile

Especificaciones Técnicas

Capacidad de Carga	20 ton	Tipo de Cadena	G100 Nickel
Altura de Izaje Estandar (Customizable)	40 ft / 12 m	Dimensiones de la Cadena	11.2 mm
Velocidad /min	5.31 ft @60Hz 1.35 mt @50Hz	Caidas de Cadena	8
Numero de Velocidades	1 Speed	Longitud de cadena	320
Voltaje	3 Phase 380V 50Hz	Humedad	20%~90%
Potencia Total Watts	7500	Temperatura	-4 ~ 104° F / -20 ~ 40° C
Clase de Servicio	H4/M5/2m/Class D	Potencia del Trolley	750+750
Protección IEC Motor	IP55	Velocidad del Trolley /min	2.75~27.55 ft @60Hz 0.7~7 mt @50Hz
Control	Pendant Control IP66 and Optional Wireless	Cantidad de Velocidades	Variable
Voltaje del Control	24V	Normas	ASME HST-1 , ASME B30.16 , B30.17 , EN60204-39
Parada de Emergencia	Yes	Garantía	3 Year
Tipo Transmisión / Reductor	Spur gearbox		

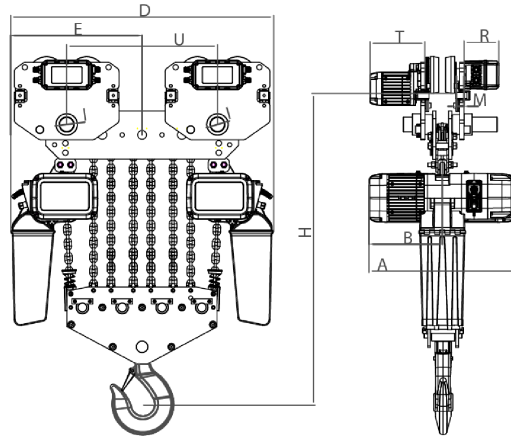

Rated load (t)	Type	Dimension (mm)												
		Minimum distance from the bottom of the track to the bottom hook: H	A	L	B	D	E	I	M	N	K	L	T	R
20	PWRXT20-08	1300	700	3500-5500	350	1246	623	71	40	80	120	96	242	167

Peso & Dimensiones

Detalles del Empaque

H Altura Muerta	1240	Paquete 1 Peso Neto	1430 lbs / 649 Kg
W Ancho	1246	Paquete 2 Peso Neto	345.4 lbs / 157 Kg
A Altura Total	1300	Paquete 1 Peso Bruto	1474 lbs / 669 Kg
J Boca Gancho	120	Paquete 2 Peso Bruto	374 lbs / 170 Kg
D Depth	700	Paquete 1 Profundidad	55 in / 139.7 cm
Peso Total (sin cable o cadena)	845	Paquete 2 Profundidad	11 in / 27.94 cm
Peso Total	1848 lbs / 839 Kg	Paquete 1 Ancho	30 in / 76.2 cm
		Paquete 2 Ancho	14 in / 35.56 cm
		Paquete 1 Altura	51 in / 129.54 cm
		Paquete 2 Altura	23 in / 58.42 cm

Referential Images / Imágenes Referenciales
Specifications may change without notice / las especificaciones pueden cambiar sin previo aviso