



## **2 ton Electric Chain Hoist w/ Power Trolley Variable Speed 380V 3Ø 50~60HZ**

### **Características Esenciales**

- 3 Años de Garantía, Servicio y Atención al Cliente en Chile

## Especificaciones Técnicas

<b>Capacidad de Carga</b>	2 ton	<b>Longitud de cadena</b>	20 ft (6 m)
<b>Voltaje</b>	3 Phase 380V 50Hz	<b>Load Chain weight per foot [lbs]</b>	1.48
<b>Altura de Izaje Estandar (Customizable)</b>	20 ft / 6 m	<b>Humedad</b>	20%~90%
<b>Velocidad /min</b>	ft @60Hz 0.8~6.8 mt @50Hz	<b>Temperatura</b>	-4 ~ 104° F / -20 ~ 40° C
<b>Numero de Velocidades</b>	Variable Speed	<b>Tipo Transmisión / Reductor</b>	Spur gearbox
<b>Hoist VFD Power</b>	4kW	<b>Reducer Lubrication Type</b>	Oil
<b>Hoist VFD Brand</b>	HUAYUAN	<b>Paint Specifications</b>	Electrostatic Sprayed Plastic (ESP) Epoxy resins, Polyester Resins, Barium, Pigments
<b>VFD Model</b>	Z230	<b>Normas</b>	ASME HST-1 , ASME B30.16 , B30.17 , EN60204-34
<b>Brake Resistor Kw</b>	1Kw	<b>Standards Certified</b>	CE
<b>Clase de Servicio</b>	H4/M5/2m/Class D	<b>Potencia del Trolley</b>	500
<b>IEC Hoist IP Protection</b>	IP55	<b>Cantidad de Velocidades</b>	Variable
<b>Protección IEC Motor</b>	IP55	<b>Velocidad del Trolley /min</b>	5.9~47.23 ft @60Hz 1.5~12 mt @50Hz
<b>Pendant Control Yes No</b>	Yes	<b>Trolley Motor Brake Type and DC Voltage</b>	DC170V
<b>IEC Pendant Control Protection</b>	IP66	<b>Trolley Motor Insulation Grade</b>	F
<b>Pendant Control Emergency Stop</b>	Yes	<b>Trolley VFD Power in KW</b>	2.5kW
<b>Pendant Control total Length</b>	17 ft	<b>Trolley VFD Brand</b>	Huayuan
<b>Hoist Motor Power in KW</b>	3	<b>Trolley VFD Model</b>	Z230
<b>Hoist Motor Brake Type and DC Voltage</b>	DC170V	<b>Trolley Wheel Diameter</b>	110
<b>Hoist Motor Insulation Grade</b>	F	<b>Trolley Wheel Material</b>	No. 45 steel
<b>Potencia Total Watts</b>	4000	<b>Trolley Minimum Turn Radius</b>	1.5
<b>Power Cord Length and Phase Order</b>	3 ft / Red L1, White L2 and Black L3, Green ground	<b>Trolley Beam Range</b>	3" to 7"
<b>Recommended Hoist Protection Circuit Breaker AMPs and Type</b>	Type D 20A	<b>Trolley Beam Extension Kit</b>	up to 12"
<b>Optional Load Chain Brand &amp; Country of Origin</b>	FEC Japan	<b>Overload Protection</b>	Overload Motor Clutch
<b>Tipo de Cadena</b>	G100 Nikel	<b>Hour Meter</b>	Internal Working Hour Meter
<b>Dimensiones de la Cadena</b>	10 mm	<b>Brake SKU</b>	PWRX-2-20-PN.60.61
<b>Caidas de Cadena</b>	1	<b>Brake rectifiers-half-wave</b>	PWRX-BKTF-HW

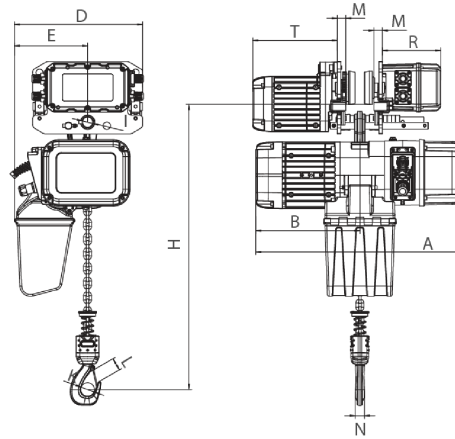

Rated load (t)	Type	Dimension (mm)													
		Minimum distance from the bottom of the track of the bottom to the bottom hook: H	A	L	B	D	E	I	M	N	K	L	T	R	
1	PWRXT1-01	473	440	3500-5500	285	210	20	105	140						
2	PWRXT2-01	516	590		276	368	210	31	24	25	42	32	242	167	
3	PWRXT3-01	600	681		350	422	264	36	28	35	52	42	242	167	
5	PWRXT5-02	645	681		350	478	307	43	30	34	59	48	242	167	

## Peso & Dimensiones

<b>A Altura Total</b>	600
<b>J Boca Gancho</b>	52
<b>W Ancho</b>	422
<b>H Altura Muerta</b>	600
<b>D Depth</b>	600
<b>1st Package Type</b>	Wood Crate
<b>Peso Total (sin cable o cadena)</b>	155
<b>2nd Package Type</b>	Wood Crate
<b>Peso Total</b>	418 lbs / 190 Kg

## Detalles del Empaque

<b>Paquete 1 Altura</b>	31 in / 78.74 cm
<b>Paquete 2 Altura</b>	23 in / 58.42 cm
<b>Paquete 1 Ancho</b>	20 in / 50.8 cm
<b>Paquete 2 Ancho</b>	14 in / 35.56 cm
<b>Paquete 1 Profundidad</b>	30 in / 76.2 cm
<b>Paquete 2 Profundidad</b>	11 in / 27.94 cm
<b>Paquete 1 Peso Neto</b>	184.8 lbs / 84 Kg
<b>Paquete 2 Peso Neto</b>	100.1 lbs / 45 Kg
<b>Paquete 1 Peso Bruto</b>	308 lbs / 140 Kg
<b>Paquete 2 Peso Bruto</b>	110 lbs / 50 Kg

Referential Images / Imágenes Referenciales  
Specifications may change without notice / las especificaciones pueden cambiar sin previo aviso