



2 ton Electric Chain Hoist w/ Power Trolley Variable Speed 110V 1Ø 60HZ

Características Esenciales

- 3 Años de Garantía, Servicio y Atención al Cliente en Chile

Especificaciones Técnicas

Optional Load Chain Brand & Country of Origin	FEC Japan	Brake rectifiers-half-wave	PWRX-BKTF-HW
Standards Certified	CE	Capacidad de Carga	2 ton
Recommended Hoist Protection Circuit Breaker AMPs and Type	Type D 20A	Altura de Izaje Estandar (Customizable)	20 ft / 6 m
Power Cord Length and Phase Order	3 ft / Black L1, White, Green ground	Velocidad /min	ft @60Hz 0.8~6.8 mt @50Hz
Pendant Control Yes No	Yes	Numero de Velocidades	Variable Speed
Pendant Control Emergency Stop	Yes	Voltaje	1 Phase 110~120V 60Hz
Paint Specifications	Electrostatic Sprayed Plastic (ESP) Epoxy resins, Polyester Resins, Barium, Pigments	Potencia Total Watts	4000
Overload Protection	Overload Motor Clutch	Clase de Servicio	H4/M5/2m/Class D
Trolley Beam Extension Kit	up to 12"	Protección IEC Motor	IP55
VFD Model	Z230	Tipo Transmisión / Reductor	Spur gearbox
Trolley Wheel Material	No. 45 steel	Tipo de Cadena	G100 Nikel
Trolley Wheel Diameter	110	Dimensiones de la Cadena	10 mm
Trolley VFD Power in KW	2.5kW	Caidas de Cadena	1
Trolley VFD Model	Z230	Longitud de cadena	20
Trolley VFD Brand	Huayuan	Humedad	20%~90%
Trolley Motor Insulation Grade	F	Temperatura	-4 ~ 104° F / -20 ~ 40° C
Brake SKU	PWRX-2-20-PN.60.61	Potencia del Trolley	500
Trolley Motor Brake Type and DC Voltage	DC170V	Velocidad del Trolley /min	5.9~47.23 ft @60Hz 1.5~12 mt @50Hz
Trolley Minimum Turn Radius	1.5	Cantidad de Velocidades	Variable
Trolley Beam Range	3" to 7"	Normas	ASME HST-1 , ASME B30.16 , B30.17 , EN60204-34
Brake Resistor Kw	1Kw	Garantía	3 Year

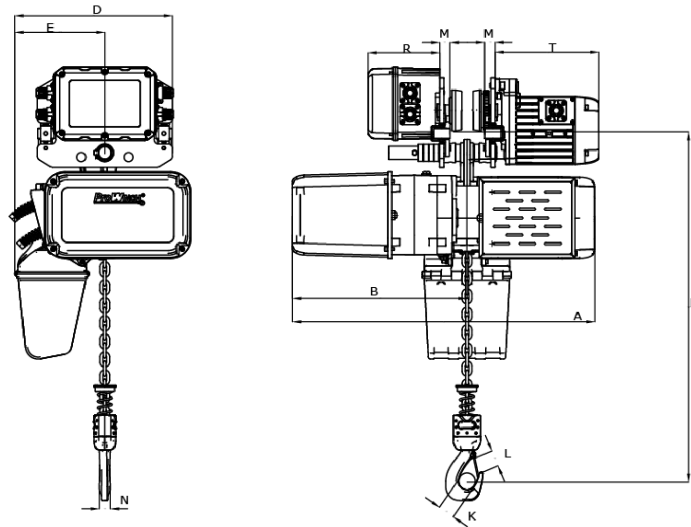

Rated load (t)	Type	Minimum distance from the bottom of the track to the bottom hook: H	Dimension (mm)											
			A	L	B	D	E	I	M	N	K	L	T	R
1	PWRXT1-VS-110V	516	704.5	3500-5500	406.5	368	210	31	24	25	42	32	242	167
2-3	PWRXT2-3-VS-110V	640	780		348	463	263	45	20	35	52	42	242	167

Peso & Dimensiones

H Altura Muerta	600
W Ancho	422
A Altura Total	600
J Boca Gancho	52
D Depth	600
Peso Total (sin cable o cadena)	155
Peso Total	418 lbs / 190 Kg

Detalles del Empaque

Paquete 1 Peso Neto	184.8 lbs / 84 Kg
Paquete 2 Peso Neto	100.1 lbs / 45 Kg
Paquete 1 Peso Bruto	308 lbs / 140 Kg
Paquete 2 Peso Bruto	110 lbs / 50 Kg
Paquete 1 Profundidad	30 in / 76.2 cm
Paquete 2 Profundidad	11 in / 27.94 cm
Paquete 1 Ancho	20 in / 50.8 cm
Paquete 2 Ancho	14 in / 35.56 cm
Paquete 1 Altura	31 in / 78.74 cm
Paquete 2 Altura	23 in / 58.42 cm

Referential Images / Imágenes Referenciales
Specifications may change without notice / las especificaciones pueden cambiar sin previo aviso