



2 ton Electric Chain Hoist w/ Power Trolley Variable Speed 440~480V 3 ϕ 1/2 50~60HZ

Características Esenciales

- 3 Años de Garantía, Servicio y Atención al Cliente en Chile

Especificaciones Técnicas

Capacidad de Carga	2 ton	Longitud de cadena	20
Voltaje	3 Phase 440~480V 60Hz	Load Chain weight per foot [lbs]	1.48
Altura de Izaje Standard (Customizable)	20 ft / 6 m	Humedad	20%~90%
Velocidad /min	3.1~26.7 ft @60Hz mt @50Hz	Temperatura	-4 ~ 104° F / -20 ~ 40° C
Numero de Velocidades	Variable Speed	Tipo Transmisión / Reductor	Spur gearbox
Hoist VFD Power	4kW	Reducer Lubrication Type	Oil
Hoist VFD Brand	HUAYUAN	Paint Specifications	Electrostatic Sprayed Plastic (ESP) Epoxy resins, Polyester Resins, Barium, Pigments
VFD Model	Z230	Normas	ASME HST-1 , ASME B30.16 , B30.17 , EN60204-34
Brake Resistor Kw	1Kw	Standards Certified	CE
Clase de Servicio	H4/M5/2m/Class D	Potencia del Trolley	500
IEC Hoist IP Protection	IP55	Cantidad de Velocidades	Variable
Protección IEC Motor	IP55	Velocidad del Trolley /min	5.9~47.23 ft @60Hz 1.5~12 mt @50Hz
Pendant Control Yes No	Yes	Trolley Motor Brake Type and DC Voltage	DC207V
IEC Pendant Control Protection	IP66	Trolley Motor Insulation Grade	F
Pendant Control Emergency Stop	Yes	Trolley VFD Power in KW	2.5kW
Pendant Control total Length	17 ft	Trolley VFD Brand	Huayuan
Hoist Motor Power in KW	3	Trolley VFD Model	Z230
Hoist Motor Brake Type and DC Voltage	DC207V	Trolley Wheel Diameter	110
Hoist Motor Insulation Grade	F	Trolley Wheel Material	No. 45 steel
Potencia Total Watts	4000	Trolley Minimum Turn Radius	1.5
Power Cord Length and Phase Order	3 ft / Black L1 , Red L2 and Blue L3 Green ground	Trolley Beam Range	3" to 7"
Recommended Hoist Protection Circuit Breaker AMPs and Type	Type D 20A	Trolley Beam Extension Kit	up to 12"
Optional Load Chain Brand & Country of Origin	FEC Japan	Overload Protection	Overload Motor Clutch
Tipo de Cadena	G100 Nikel	Hour Meter	Internal Working Hour Meter
Dimensiones de la Cadena	10 mm	Brake SKU	PWRX-2-20-PN.60.61
Caidas de Cadena	1	Brake rectifiers-half-wave	PWRX-BKTF-HW

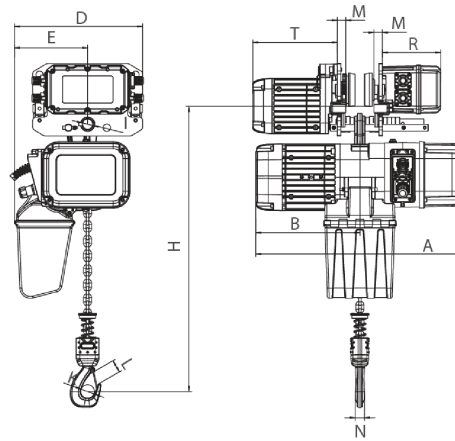

Rated load (t)	Type	Dimension (mm)													
		Minimum distance from the bottom of the track of the bottom to the bottom hook: H	A	L	B	D	E	I	M	N	K	L	T	R	
1	PWRXT1-01	473	440	3500-5500	285	210	20	105	140						
2	PWRXT2-01	516	590		276	368	210	31	24	25	42	32	242	167	
3	PWRXT3-01	600	681		350	422	264	36	28	35	52	42	242	167	
5	PWRXT5-02	645	681		350	478	307	43	30	34	59	48	242	167	

Peso & Dimensiones

A Altura Total	600
J Boca Gancho	52
W Ancho	422
H Altura Muerta	600
D Depth	600
1st Package Type	Wood Crate
Peso Total (sin cable o cadena)	155
2nd Package Type	Wood Crate
Peso Total	418 lbs / 190 Kg

Detalles del Empaque

Paquete 1 Altura	31 in / 78.74 cm
Paquete 2 Altura	23 in / 58.42 cm
Paquete 1 Ancho	20 in / 50.8 cm
Paquete 2 Ancho	14 in / 35.56 cm
Paquete 1 Profundidad	30 in / 76.2 cm
Paquete 2 Profundidad	11 in / 27.94 cm
Paquete 1 Peso Neto	184.8 lbs / 84 Kg
Paquete 2 Peso Neto	100.1 lbs / 45 Kg
Paquete 1 Peso Bruto	308 lbs / 140 Kg
Paquete 2 Peso Bruto	110 lbs / 50 Kg

Referential Images / Imágenes Referenciales
Specifications may change without notice / las especificaciones pueden cambiar sin previo aviso