



2 ton Electric Chain Hoist w/ Power Trolley 2 Speed 208~240V / 440~480V 3ph 60HZ

Características Esenciales

- 3 Años de Garantía, Servicio y Atención al Cliente en Chile

Especificaciones Técnicas

Trolley Contactors Brand	Schneider	Numero de Velocidades	2 Speed
Optional Load Chain Brand & Country of Origin	FEC Japan	Voltaje	3 Phase 208~240/440~480V 50/60Hz
Paint Specifications	Electrostatic Sprayed Plastic (ESP) Epoxy resins, Polyester Resins, Barium, Pigments	Potencia Total Watts	3500
Trolley Beam Extension Kit	up to 12"	Clase de Servicio	H4/M5/2m/Class D
Trolley Beam Range	3" to 7"	Protección IEC Motor	IP55
Trolley Minimum Turn Radius	1.5	Control	Pendant Control IP66 and Optional Wireless
Trolley Wheel Material	No. 45 steel	Voltaje del Control	24V
Trolley Wheel Diameter	110	Parada de Emergencia	Yes
Trolley Contactors Coil Voltage	24 V	Hoist Contactor Brand	Schneider
Trolley Contactors Amps	32A	Tipo Transmisión / Reductor	Spur gearbox
Trolley Motor Insulation Grade	F	Tipo de Cadena	G100 Níquel
Trolley Motor Brake Type and DC Voltage	DC99V/DC207V	Dimensiones de la Cadena	10 mm
Pendant Control Yes No	Yes	Caidas de Cadena	1
Pendant Control Emergency Stop	Yes	Longitud de cadena	20
Standards Certified	CE	Humedad	20%~90%
Overload Protection	Overload Motor Clutch	Temperatura	-4 ~ 104° F / -20 ~ 40° C
Brake SKU	PWRX-2-20-PN.60.61	Potencia del Trolley	500
Brake rectifiers-half-wave	PWRX-BKTF-HW	Velocidad del Trolley /min	14.17~43.30 ft @60Hz 3.6~11 mt @50Hz
Power Cord Length and Phase Order	3 ft / Black L1 , Red L2 and Blue L3 Green ground	Cantidad de Velocidades	2
Recommended Hoist Protection Circuit Breaker AMPs and Type	Type D 25A at 220V and 20A at 460V	Rango de ancho de la Viga	3" to 7"
Capacidad de Carga	2 ton	Radio Minimo de Giro	1.5
Altura de Izaje Estandard (Customizable)	20 ft / 6 m	Normas	ASME HST-1 , ASME B30.16 , B30.17 , EN60204-34
Velocidad /min	8.7/ 26.8 ft @60Hz 2.2/6.8 mt @50Hz	Garantía	3 Year

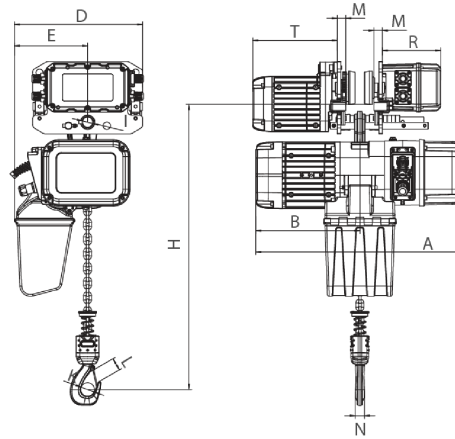

Rated load (t)	Type	Dimension (mm)													
		Minimum distance from the bottom of the track to the bottom hook: H	A	L	B	D	E	I	M	N	K	L	T	R	
1	PWRXT1-01	473	440	3500-5500	285	210	20	105	140						
2	PWRXT2-01	516	590		276	368	210	31	24	25	42	32	242	167	
3	PWRXT3-01	600	681		350	422	264	36	28	35	52	42	242	167	
5	PWRXT5-02	645	681		350	478	307	43	30	34	59	48	242	167	

Peso & Dimensiones

H Altura Muerta	600
W Ancho	422
A Altura Total	600
J Boca Gancho	52
D Depth	600
Peso Total (sin cable o cadena)	155
Peso Total	544 lbs / 247 Kg

Detalles del Empaque

Paquete 1 Peso Neto	184.8 lbs / 84 Kg
Paquete 1 Ancho	24 in / 60.96 cm
Paquete 1 Peso Bruto	544 lbs / 247 Kg
Paquete 1 Altura	44 in / 111.76 cm
Paquete 1 Profundidad	30 in / 76.2 cm

Referential Images / Imágenes Referenciales
Specifications may change without notice / las especificaciones pueden cambiar sin previo aviso