



2 ton Electric Chain Hoist w/ Power Trolley 1 Speed 208~240V / 440~480V 3 ϕ 1/2 60HZ

Especificaciones Técnicas

Capacidad de Carga	2 ton	Humedad	20%~90%
Voltaje	3 Phase 208~240/440~480V 50/60Hz	Temperatura	-4 ~ 104° F / -20 ~ 40° C
Altura de Izaje Estandar (Customizable)	20 ft / 6 m	Tipo Transmisión / Reductor	Spur gearbox
Velocidad /min	26.77 ft @60Hz 6.80 mt @50Hz	Reducer Lubrication Type	Oil
Numero de Velocidades	1 Speed	Paint Specifications	Electrostatic Sprayed Plastic (ESP) Epoxy resins, Polyester Resins, Barium, Pigments
Hoist Contactors Amps	25A	Normas	ASME HST-1 , ASME B30.16 , B30.17 , EN60204-34
Hoist Contactor Brand	Schneider	Standards Certified	CE
Hoist Contactor Coil Voltage	24 V	Potencia del Trolley	500
Clase de Servicio	H4/M5/2m/Class D	Cantidad de Velocidades	1
IEC Hoist IP Protection	IP55	Velocidad del Trolley /min	43.30 ft @60Hz 11 mt @50Hz
Protección IEC Motor	IP55	Trolley Motor Brake Type and DC Voltage	DC99V/DC207V
Pendant Control Yes No	Yes	Trolley Motor Insulation Grade	F
IEC Pendant Control Protection	IP66	Trolley Contactors Amps	32A
Pendant Control Emergency Stop	Yes	Trolley Contactors Brand	Schneider
Pendant Control total Length	17 ft	Trolley Contactors Brand	Schneider
Hoist Motor Power in KW	3	Trolley Contactors Coil Voltage	24 V

Optional Load Chain Brand & Country of Origin	FEC Japan	Overload Protection	Overload Motor Clutch
Tipo de Cadena	G100 Nikel	Hour Meter	Internal Working Hour Meter
Dimensiones de la Cadena	10 mm	Brake SKU	PWRX-2-20-PN.60.61
Caidas de Cadena	1	Brake rectifiers-half-wave	PWRX-BKTF-HW
Longitud de cadena	20	Brake rectifiers-full-wave	PWRX-BKTF-FW
Load Chain weight per foot [lbs]	1.48		

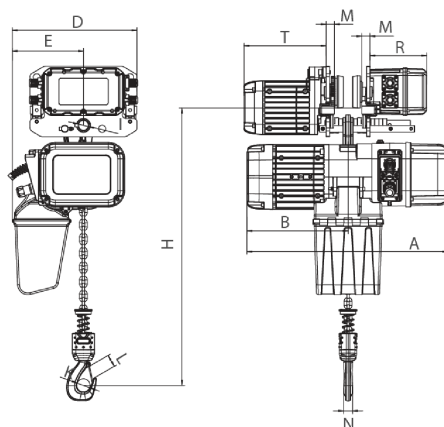

Rated load (t)	Type	Dimension (mm)												
		Minimum distance from the bottom of the track to the bottom hook: H	A	L	B	D	E	I	M	N	K	L	T	R
1	PWRXT1-01	473	440	3500-5500	285	210	20	105	140					
2	PWRXT2-01	516	590		276	368	210	31	24	25	42	32	242	167
3	PWRXT3-01	600	681		350	422	264	36	28	35	52	42	242	167
5	PWRXT5-02	645	681		350	478	307	43	30	34	59	48	242	167

Peso & Dimensiones

A Altura Total	540
J Boca Gancho	52
W Ancho	420
H Altura Muerta	600
D Depth	695
1st Package Type	Wood Crate
Peso Total (sin cable o cadena)	155
2nd Package Type	Wood Crate
Peso Total	418 lbs / 190 Kg

Detalles del Empaque

Paquete 1 Altura	31 in / 78.74 cm
Paquete 2 Altura	23 in / 58.42 cm
Paquete 1 Ancho	20 in / 50.8 cm
Paquete 2 Ancho	14 in / 35.56 cm
Paquete 1 Profundidad	30 in / 76.2 cm
Paquete 2 Profundidad	11 in / 27.94 cm
Paquete 1 Peso Neto	184.8 lbs / 84 Kg
Paquete 2 Peso Neto	100.1 lbs / 45 Kg
Paquete 1 Peso Bruto	308 lbs / 140 Kg
Paquete 2 Peso Bruto	110 lbs / 50 Kg

