



## 10 ton Electric Chain Hoist w/ Power Trolley Variable Speed Trolley 380V 3ø, 50HZ 40ft G100 Nickel Duty H4/M5

### Características Esenciales

- 3 Años de Garantía, Servicio y Atención al Cliente en Chile

## Especificaciones Técnicas

<b>Capacidad de Carga</b>	10 ton	<b>Tipo de Cadena</b>	G100 Nickel
<b>Altura de Izaje Estandar (Customizable)</b>	40 ft / 12 m	<b>Dimensiones de la Cadena</b>	11.2 mm
<b>Velocidad /min</b>	10.63 ft @60Hz 2.70 mt @50Hz	<b>Caidas de Cadena</b>	4
<b>Numero de Velocidades</b>	1 Speed	<b>Longitud de cadena</b>	160
<b>Voltaje</b>	3 Phase 380V 50Hz	<b>Humedad</b>	20%~90%
<b>Potencia Total Watts</b>	6750	<b>Temperatura</b>	-4 ~ 104° F / -20 ~ 40° C
<b>Clase de Servicio</b>	H4/M5/2m/Class D	<b>Potencia del Trolley</b>	750
<b>Protección IEC Motor</b>	IP55	<b>Velocidad del Trolley /min</b>	2.75~27.55 ft @60Hz 0.7~7 mt @50Hz
<b>Control</b>	Pendant Control IP66 and Optional Wireless	<b>Cantidad de Velocidades</b>	Variable
<b>Voltaje del Control</b>	24V	<b>Normas</b>	ASME HST-1 , ASME B30.16 , B30.17 , EN60204-38
<b>Parada de Emergencia</b>	Yes	<b>Garantía</b>	3 Year
<b>Tipo Transmisión / Reductor</b>	Spur gearbox		

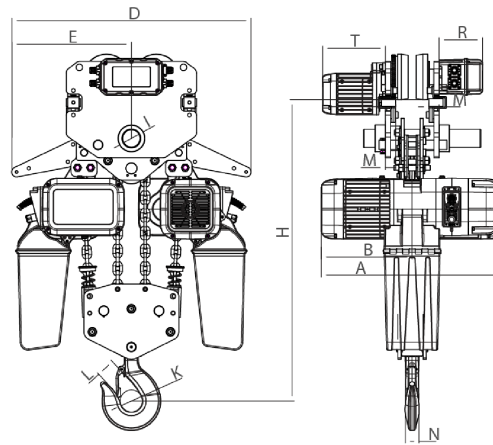

Rated load (t)	Type	Dimension (mm)													
		Minimum distance from the bottom of the track to the bottom hook: H	A	L	B	D	E	I	M	N	K	L	T	R	
10	PWRXT10-04	1045	700	3500-5500	350	920	460	70	39	48	85	80	242	167	

### Peso & Dimensiones

H Altura Muerta	1005
W Ancho	920
A Altura Total	1045
J Boca Gancho	85
D Depth	700
Peso Total (sin cable o cadena)	345
Peso Total	869 lbs / 395 Kg

### Detalles del Empaque

Paquete 1 Peso Neto	638 lbs / 289 Kg
Paquete 2 Peso Neto	172.7 lbs / 78 Kg
Paquete 1 Peso Bruto	682 lbs / 309 Kg
Paquete 2 Peso Bruto	187 lbs / 85 Kg
Paquete 1 Profundidad	44 in / 111.76 cm
Paquete 2 Profundidad	11 in / 27.94 cm
Paquete 1 Ancho	30 in / 76.2 cm
Paquete 2 Ancho	14 in / 35.56 cm
Paquete 1 Altura	40 in / 101.6 cm
Paquete 2 Altura	23 in / 58.42 cm

Referential Images / Imágenes Referenciales  
Specifications may change without notice / las especificaciones pueden cambiar sin previo aviso