



## **10 ton Electric Chain Hoist w/ Power Trolley Variable Speed Trolley 208~240V / 440~480V 3Å, 60HZ**

### **Características Esenciales**

- 3 Años de Garantía, Servicio y Atención al Cliente en Chile

## Especificaciones Técnicas

Capacidad de Carga	10 ton	Load Chain weight per foot [lbs]	1.83
Voltaje	3 Phase 208~240/440~480V 50/60Hz	Humedad	20%~90%
Altura de Izaje Estandar (Customizable)	40 ft / 12 m	Temperatura	-4 ~ 104° F / -20 ~ 40° C
Velocidad /min	10.63 ft @60Hz 2.70 mt @50Hz	Tipo Transmisión / Reductor	Spur gearbox
Numero de Velocidades	1 Speed	Reducer Lubrication Type	Oil
Hoist Contactors Amps	25A	Paint Specifications	Electrostatic Sprayed Plastic (ESP) Epoxy resins, Polyester Resins, Barium, Pigments
Hoist Contactor Brand	Schneider	Normas	ASME HST-1 , ASME B30.16 , B30.17 , EN60204-38
Hoist Contactor Coil Voltage	24 V	Standards Certified	CE
Clase de Servicio	H4/M5/2m/Class D	Potencia del Trolley	750
IEC Hoist IP Protection	IP55	Cantidad de Velocidades	Variable
Protección IEC Motor	IP55	Velocidad del Trolley /min	2.75~27.55 ft @60Hz 0.7~7 mt @50Hz
Pendant Control Yes No	Yes	Trolley Motor Brake Type and DC Voltage	DC99V/DC207V
IEC Pendant Control Protection	IP66	Trolley Motor Insulation Grade	F
Pendant Control Emergency Stop	Yes	Trolley VFD Power in KW	2.5kW
Pendant Control total Length	37 ft	Trolley VFD Brand	z-230
Hoist Motor Power in KW	3+3	Trolley VFD Model	huayuan
Hoist Motor Brake Type and DC Voltage	DC99V/DC207V	Trolley Wheel Diameter	139
Hoist Motor Insulation Grade	F	Trolley Wheel Material	No. 45 steel
Potencia Total Watts	6750	Trolley Minimum Turn Radius	2
Power Cord Length and Phase Order	3 ft / Black L1 , Red L2 and Blue L3]Green ground	Trolley Beam Range	3.9" to 7"
Recommended Hoist Protection Circuit Breaker AMPs and Type	Type D 50A at 220V and 30A at 460V	Trolley Beam Extension Kit	up to 12"
Optional Load Chain Brand & Country of Origin	FEC Japan	Overload Protection	Overload Motor Clutch
Tipo de Cadena	G100 Nikel	Hour Meter	Internal Working Hour Meter
Dimensiones de la Cadena	11.2 mm	Brake SKU	PWRX-2-20-PN.60.61
Caidas de Cadena	4	Brake rectifiers-half-wave	PWRX-BKTF-HW
Longitud de cadena	160	Brake rectifiers-full-wave	PWRX-BKTF-FW

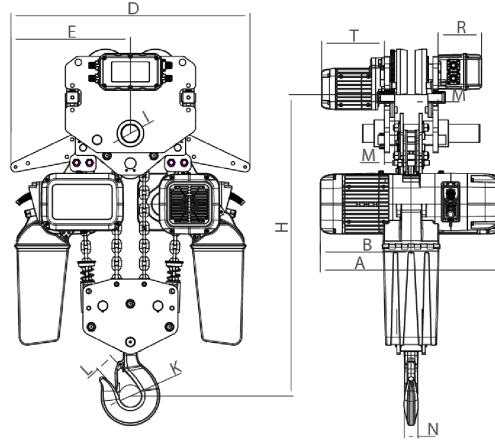

Rated load (t)	Type	Dimension (mm)												
		Minimum distance from the bottom of the track to the bottom hook: H	A	L	B	D	E	I	M	N	K	L	T	R
10	PWRXT10-04	1045	700	3500-5500	350	920	460	70	39	48	85	80	242	167

### Peso & Dimensiones

<b>A Altura Total</b>	1045
<b>J Boca Gancho</b>	85
<b>W Ancho</b>	920
<b>H Altura Muerta</b>	1005
<b>D Depth</b>	700
<b>1st Package Type</b>	Wood Crate
<b>Peso Total (sin cable o cadena)</b>	345
<b>2nd Package Type</b>	Wood Crate
<b>Peso Total</b>	869 lbs / 395 Kg

### Detalles del Empaque

<b>Paquete 1 Altura</b>	40 in / 101.6 cm
<b>Paquete 2 Altura</b>	23 in / 58.42 cm
<b>Paquete 1 Ancho</b>	30 in / 76.2 cm
<b>Paquete 2 Ancho</b>	14 in / 35.56 cm
<b>Paquete 1 Profundidad</b>	44 in / 111.76 cm
<b>Paquete 2 Profundidad</b>	11 in / 27.94 cm
<b>Paquete 1 Peso Neto</b>	638 lbs / 289 Kg
<b>Paquete 2 Peso Neto</b>	172.7 lbs / 78 Kg
<b>Paquete 1 Peso Bruto</b>	682 lbs / 309 Kg
<b>Paquete 2 Peso Bruto</b>	187 lbs / 85 Kg

Referential Images / Imágenes Referenciales  
Specifications may change without notice / las especificaciones pueden cambiar sin previo aviso