



1 ton Electric Chain Hoist w/ Power Trolley Variable Speed 440~480V 3Ø 50~60HZ

Características Esenciales

- 3 Años de Garantía, Servicio y Atención al Cliente en Chile

Especificaciones Técnicas

Capacidad de Carga	1 ton	Tipo de Cadena	G100 Nickel
Altura de Izaje Estandar (Customizable)	20 ft / 6 m	Dimensiones de la Cadena	7.1 mm
Velocidad /min	3.1~27.5 ft @60Hz mt @50Hz	Caidas de Cadena	1
Numero de Velocidades	Variable Speed	Longitud de cadena	20
Voltaje	3 Phase 440~480V 60Hz	Humedad	20%~90%
Potencia Total Watts	4000	Temperatura	-4 ~ 104° F / -20 ~ 40° C
Clase de Servicio	H4/M5/2m/Class D	Potencia del Trolley	500
Protección IEC Motor	IP55	Velocidad del Trolley /min	5.9~47.23 ft @60Hz 1.5~12 mt @50Hz
Control	Pendant Control IP66 and Optional Wireless	Cantidad de Velocidades	Variable
Voltaje del Control	24V	Normas	ASME HST-1 , ASME B30.16 , B30.17 , EN60204-33
Parada de Emergencia	Yes	Garantía	3 Year
Tipo Transmisión / Reductor	Spur gearbox		

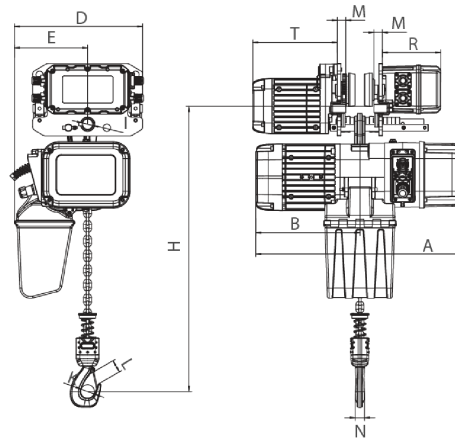

Rated load (t)	Type	Dimension (mm)													
		Minimum distance from the bottom of the track of the bottom to the bottom hook: H	A	L	B	D	E	I	M	N	K	L	T	R	
1	PWRXT1-01	473	440	3500-5500	285	210	20	105	140						
2	PWRXT2-01	516	590		276	368	210	31	24	25	42	32	242	167	
3	PWRXT3-01	600	681		350	422	264	36	28	35	52	42	242	167	
5	PWRXT5-02	645	681		350	478	307	43	30	34	59	48	242	167	

Peso & Dimensiones

H Altura Muerta	516
W Ancho	368
A Altura Total	516
J Boca Gancho	42
D Depth	590
Peso Total (sin cable o cadena)	86
Peso Total	308 lbs / 140 Kg

Detalles del Empaque

Paquete 1 Peso Neto	101.64 lbs / 46 Kg
Paquete 2 Peso Neto	89.1 lbs / 40 Kg
Paquete 1 Peso Bruto	209 lbs / 95 Kg
Paquete 2 Peso Bruto	99 lbs / 45 Kg
Paquete 1 Profundidad	26 in / 66.04 cm
Paquete 2 Profundidad	11 in / 27.94 cm
Paquete 1 Ancho	16 in / 40.64 cm
Paquete 2 Ancho	14 in / 35.56 cm
Paquete 1 Altura	26 in / 66.04 cm
Paquete 2 Altura	23 in / 58.42 cm

Referential Images / Imágenes Referenciales
Specifications may change without notice / las especificaciones pueden cambiar sin previo aviso