



1 ton Electric Chain Hoist w/ Power Trolley 2 Speed 380V 3ø 50HZ

Características Esenciales

- 3 Años de Garantía, Servicio y Atención al Cliente en Chile

Especificaciones Técnicas

Capacidad de Carga	1 ton	Longitud de cadena	20
Altura de Izaje Estandar (Customizable)	20 ft / 6 m	Humedad	20%~90%
Velocidad /min	7.8/42.6 ft @60Hz 2/6.5 mt @50Hz	Temperatura	-4 ~ 104° F / -20 ~ 40° C
Numero de Velocidades	2 Speed	Radio Minimo de Giro	1.3
Voltaje	3 Phase 380V 50Hz	Normas	ASME HST-1 , ASME B30.16 , B30.17 , EN60204-33
Potencia Total Watts	2000	Garantía	3 Year
Clase de Servicio	H4/M5/2m/Class D	Hoist Motor Power in KW	1.5
Protección IEC Motor	IP55	Hour Meter	Internal Working Hour Meter
Control	Pendant Control IP66 and Optional Wireless	Hoist Motor Insulation Grade	F
Voltaje del Control	24V	Hoist Contactor Coil Voltage	24 V
Parada de Emergencia	Yes	Hoist Contactors Amps	18A
Tipo Transmisión / Reductor	Spur gearbox	Hoist Contactor Brand	Schneider
Tipo de Cadena	G100 Nikel	IEC Hoist IP Protection	IP55
Dimensiones de la Cadena	7.1 mm	IEC Pendant Control Protection	IP66
Caidas de Cadena	1	Hoist Motor Brake Type and DC Voltage	DC170V

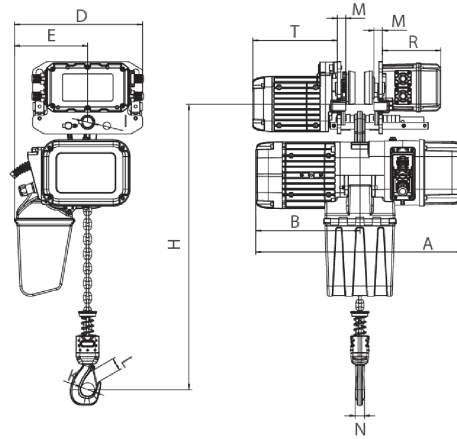

Rated load (t)	Type	Dimension (mm)													
		Minimum distance from the bottom of the track of the bottom to the bottom hook: H	A	L	B	D	E	I	M	N	K	L	T	R	
1	PWRXT1-01	473	440	3500-5500	285	210	20	105	140						
2	PWRXT2-01	516	590		276	368	210	31	24	25	42	32	242	167	
3	PWRXT3-01	600	681		350	422	264	36	28	35	52	42	242	167	
5	PWRXT5-02	645	681		350	478	307	43	30	34	59	48	242	167	

Peso & Dimensiones

H Altura Muerta	516
J Boca Gancho	42
A Altura Total	516
Peso Total (sin cable o cadena)	86
D Depth	590
1st Package Type	Wood Crate
W Ancho	368
2nd Package Type	Wood Crate
Peso Total	308 lbs / 140 Kg

Detalles del Empaque

Paquete 1 Peso Neto	101.64 lbs / 46 Kg
Paquete 2 Peso Neto	89.1 lbs / 40 Kg
Paquete 1 Peso Bruto	209 lbs / 95 Kg
Paquete 2 Peso Bruto	99 lbs / 45 Kg
Paquete 1 Profundidad	26 in / 66.04 cm
Paquete 2 Profundidad	8 in / 20.32 cm
Paquete 1 Ancho	16 in / 40.64 cm
Paquete 2 Ancho	13 in / 33.02 cm
Paquete 1 Altura	26 in / 66.04 cm
Paquete 2 Altura	20 in / 50.8 cm

Referential Images / Imágenes Referenciales
Specifications may change without notice / las especificaciones pueden cambiar sin previo aviso