



1 ton Electric Chain Hoist w/ Power Trolley 2 Speed 208~240V / 440~480V 3ph 60HZ

Características Esenciales

- 3 Años de Garantía, Servicio y Atención al Cliente en Chile

Especificaciones Técnicas

Paint Specifications	Electrostatic Sprayed Plastic (ESP) Epoxy resins, Polyester Resins, Barium, Pigments	Numero de Velocidades	2 Speed
Trolley Minimum Turn Radius	1.3	Voltaje	3 Phase 208~240/440~480V 50/60Hz
Trolley Wheel Material	No. 45 steel	Potencia Total Watts	2000
Trolley Wheel Diameter	95	Clase de Servicio	H4/M5/2m/Class D
Trolley Contactors Coil Voltage	24 V	Protección IEC Motor	IP55
Trolley Contactors Brand	Schneider	Control	Pendant Control IP66 and Optional Wireless
Trolley Contactors Amps	32A	Voltaje del Control	24V
Trolley Motor Insulation Grade	F	Parada de Emergencia	Yes
Trolley Motor Brake Type and DC Voltage	DC99V/DC207V	Hoist Contactor Brand	Schneider
Standards Certified	CE	Tipo Transmisión / Reductor	Spur gearbox
Optional Load Chain Brand & Country of Origin	FEC Japan	Tipo de Cadena	G100 Nikel
Recommended Hoist Protection Circuit Breaker AMPs and Type	Type D 20A at 220V and 15A at 460V	Dimensiones de la Cadena	7.1 mm
Power Cord Length and Phase Order	3 ft / Black L1 , Red L2 and Blue L3□Green ground	Caidas de Cadena	1
Brake rectifiers-half-wave	PWRX-BKTF-HW	Longitud de cadena	20
Brake SKU	PWRX-1-PN.60.61	Humedad	20%~90%
Overload Protection	Overload Motor Clutch	Temperatura	-4 ~ 104° F / -20 ~ 40° C
Pendant Control Emergency Stop	Yes	Potencia del Trolley	500
Pendant Control Yes No	Yes	Velocidad del Trolley /min	14.17~43.30 ft @60Hz 3.6~11 mt @50Hz
Trolley Beam Extension Kit	up to 12"	Cantidad de Velocidades	2
Trolley Beam Range	2" to 6"	Rango de ancho de la Viga	2" to 6"
Capacidad de Carga	1 ton	Radio Minimo de Giro	1.3
Altura de Izaje Estandard (Customizable)	20 ft / 6 m	Normas	ASME HST-1 , ASME B30.16 , B30.17 , EN60204-33
Velocidad /min	7.9/ 42.7 ft @60Hz 2/6.5 mt @50Hz	Garantía	3 Year

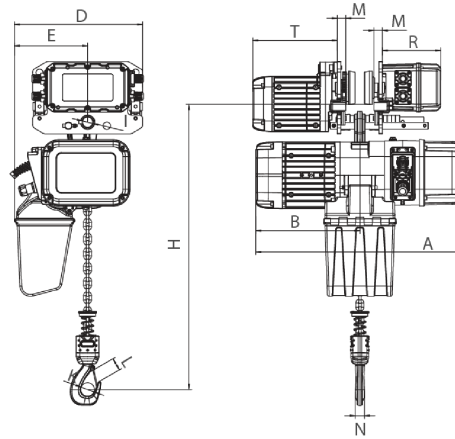

Rated load (t)	Type	Dimension (mm)													
		Minimum distance from the bottom of the track to the bottom hook: H	A	L	B	D	E	I	M	N	K	L	T	R	
1	PWRXT1-01	473	440	3500-5500	285	210	20	105	140						
2	PWRXT2-01	516	590		276	368	210	31	24	25	42	32	242	167	
3	PWRXT3-01	600	681		350	422	264	36	28	35	52	42	242	167	
5	PWRXT5-02	645	681		350	478	307	43	30	34	59	48	242	167	

Peso & Dimensiones

H Altura Muerta	516
W Ancho	368
A Altura Total	516
J Boca Gancho	42
D Depth	590
Peso Total (sin cable o cadena)	86
Peso Total	244 lbs / 111 Kg

Detalles del Empaque

Paquete 1 Peso Neto	101.64 lbs / 46 Kg
Paquete 1 Ancho	16 in / 40.64 cm
Paquete 1 Peso Bruto	244 lbs / 111 Kg
Paquete 1 Altura	38 in / 96.52 cm
Paquete 1 Profundidad	26 in / 66.04 cm

Referential Images / Imágenes Referenciales
Specifications may change without notice / las especificaciones pueden cambiar sin previo aviso