



1 ton Electric Chain Hoist w/ Power Trolley 1 Speed 380V 3Ø 50HZ

Especificaciones Técnicas

Capacidad de Carga	1 ton	Load Chain weight per foot [lbs]	0.58
Voltaje	3 Phase 380V 50Hz	Humedad	20%~90%
Altura de Izaje Estandar (Customizable)	20 ft / 6 m	Temperatura	-4 ~ 104° F / -20 ~ 40° C
Velocidad /min	25.60 ft @60Hz 6.50 mt @50Hz	Tipo Transmisión / Reductor	Spur gearbox
Numero de Velocidades	1 Speed	Reducer Lubrication Type	Oil
Hoist Contactors Amps	18A	Paint Specifications	Electrostatic Sprayed Plastic (ESP) Epoxy resins, Polyester Resins, Barium, Pigments
Hoist Contactor Brand	Schneider	Normas	ASME HST-1 , ASME B30.16 , B30.17 , EN60204-33
Hoist Contactor Coil Voltage	24 V	Standards Certified	CE
Clase de Servicio	H4/M5/2m/Class D	Potencia del Trolley	500
IEC Hoist IP Protection	IP55	Cantidad de Velocidades	1
Protección IEC Motor	IP55	Velocidad del Trolley /min	43.30 ft @60Hz 11 mt @50Hz
Pendant Control Yes No	Yes	Trolley Motor Brake Type and DC Voltage	DC170V
IEC Pendant Control Protection	IP66	Trolley Motor Insulation Grade	F
Pendant Control Emergency Stop	Yes	Trolley Contactors Amps	32A
Pendant Control total Length	17 ft	Trolley Contactors Brand	Schneider
Hoist Motor Power in KW	1.5	Trolley Contactors Brand	Schneider

Optional Load Chain Brand & Country of Origin	FEC Japan	Trolley Beam Extension Kit	up to 12"
Tipo de Cadena	G100 Nikel	Overload Protection	Overload Motor Clutch
Dimensiones de la Cadena	7.1 mm	Hour Meter	Internal Working Hour Meter
Caidas de Cadena	1	Brake SKU	PWRX-1-PN.60.61
Longitud de cadena	20	Brake rectifiers-half-wave	PWRX-BKTF-HW

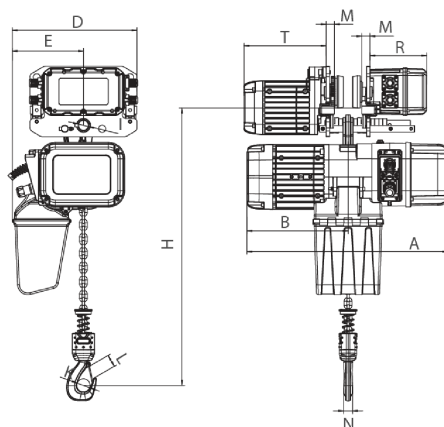

Rated load (t)	Type	Dimension (mm)												
		Minimum distance from the bottom of the track to the bottom hook: H	A	L	B	D	E	I	M	N	K	L	T	R
1	PWRXT1-01	473	440	3500-5500	285	210	20	105	140					
2	PWRXT2-01	516	590		276	368	210	31	24	25	42	32	242	167
3	PWRXT3-01	600	681		350	422	264	36	28	35	52	42	242	167
5	PWRXT5-02	645	681		350	478	307	43	30	34	59	48	242	167

Peso & Dimensiones

A Altura Total	455
J Boca Gancho	42
W Ancho	330
H Altura Muerta	516
D Depth	590
1st Package Type	Wood Crate
Peso Total (sin cable o cadena)	90
2nd Package Type	Wood Crate
Peso Total	279.4 lbs / 127 Kg

Detalles del Empaque

Paquete 1 Altura	26 in / 66.04 cm
Paquete 2 Altura	20 in / 50.8 cm
Paquete 1 Ancho	16 in / 40.64 cm
Paquete 2 Ancho	13 in / 33.02 cm
Paquete 1 Profundidad	26 in / 66.04 cm
Paquete 2 Profundidad	8 in / 20.32 cm
Paquete 1 Peso Neto	101.64 lbs / 46 Kg
Paquete 2 Peso Neto	62.48 lbs / 28 Kg
Paquete 1 Peso Bruto	209 lbs / 95 Kg
Paquete 2 Peso Bruto	70.4 lbs / 32 Kg

