



## **1/2 ton Electric Chain Hoist w/ Power Trolley Variable Speed 440~480V 3ø 50~60HZ**

### **Características Esenciales**

- 3 Años de Garantía, Servicio y Atención al Cliente en Chile

## Especificaciones Técnicas

<b>Capacidad de Carga</b>	1/2 ton	<b>Longitud de cadena</b>	13
<b>Voltaje</b>	3 Phase 440~480V 60Hz	<b>Load Chain weight per foot [lbs]</b>	0.58
<b>Altura de Izaje Estandar (Customizable)</b>	13 ft / 4 m	<b>Humedad</b>	20%~90%
<b>Velocidad /min</b>	3.9~31.5 ft @60Hz mt @50Hz	<b>Temperatura</b>	-4 ~ 104° F / -20 ~ 40° C
<b>Numero de Velocidades</b>	Variable Speed	<b>Tipo Transmisión / Reductor</b>	Spur gearbox
<b>Hoist VFD Power</b>	1.5kW	<b>Reducer Lubrication Type</b>	Oil
<b>Hoist VFD Brand</b>	HUAYUAN	<b>Paint Specifications</b>	Electrostatic Sprayed Plastic (ESP) Epoxy resins, Polyester Resins, Barium, Pigments
<b>VFD Model</b>	Z230	<b>Normas</b>	ASME HST-1 , ASME B30.16 , EN60204-37
<b>Brake Resistor Kw</b>	0.3Kw	<b>Standards Certified</b>	CE
<b>Clase de Servicio</b>	H4/M5/2m/Class D	<b>Potencia del Trolley</b>	500
<b>IEC Hoist IP Protection</b>	IP55	<b>Cantidad de Velocidades</b>	Variable
<b>Protección IEC Motor</b>	IP55	<b>Velocidad del Trolley /min</b>	5.9~47.23 ft @60Hz 1.5~12 mt @50Hz
<b>Pendant Control Yes No</b>	Yes	<b>Trolley Motor Brake Type and DC Voltage</b>	DC207V
<b>IEC Pendant Control Protection</b>	IP66	<b>Trolley Motor Insulation Grade</b>	F
<b>Pendant Control Emergency Stop</b>	Yes	<b>Trolley VFD Power in KW</b>	2.5kW
<b>Pendant Control total Length</b>	10 ft	<b>Trolley VFD Brand</b>	Huayuan
<b>Hoist Motor Power in KW</b>	0.75	<b>Trolley VFD Model</b>	Z230
<b>Hoist Motor Brake Type and DC Voltage</b>	DC207V	<b>Trolley Wheel Diameter</b>	95
<b>Hoist Motor Insulation Grade</b>	F	<b>Trolley Wheel Material</b>	No. 45 steel
<b>Potencia Total Watts</b>	1500	<b>Trolley Minimum Turn Radius</b>	1.3
<b>Power Cord Length and Phase Order</b>	3 ft / Black L1 , Red L2 and Blue L3 Green ground	<b>Trolley Beam Range</b>	3" to 5"
<b>Recommended Hoist Protection Circuit Breaker AMPS and Type</b>	Type D 10A	<b>Trolley Beam Extension Kit</b>	up to 12"
<b>Optional Load Chain Brand &amp; Country of Origin</b>	FEC Japan	<b>Overload Protection</b>	Overload Motor Clutch
<b>Tipo de Cadena</b>	G100 Nikel	<b>Hour Meter</b>	Internal Working Hour Meter
<b>Dimensiones de la Cadena</b>	6.3mm	<b>Brake SKU</b>	PWRX-0.25-0.5-PN.4.11
<b>Caidas de Cadena</b>	1	<b>Brake rectifiers-half-wave</b>	PWRX-BKTF-HW

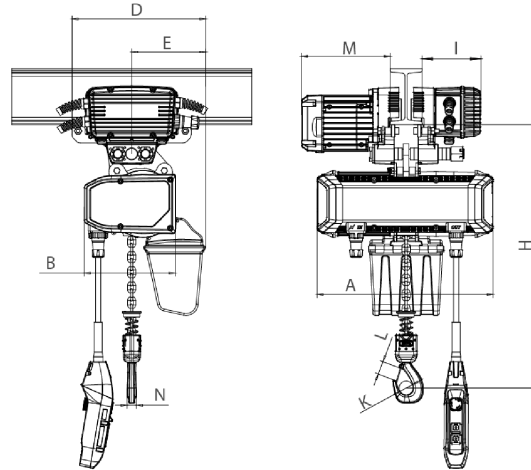

Rated load (t)	Type	Dimension (mm)									
		Minimum distance from the bottom of the track to the bottom hook: H	A	L	B	D	E	I	M	N	K
0.25-0.5	PWRXT0.25-0.5-VS	473	447	3500-5500	217	334	152	147	220	20	35

## Peso & Dimensiones

<b>A Altura Total</b>	396	<b>Paquete 1 Altura</b>	20 in / 50.8 cm
<b>J Boca Gancho</b>	35	<b>Paquete 2 Altura</b>	20 in / 50.8 cm
<b>W Ancho</b>	305	<b>Paquete 1 Ancho</b>	15 in / 38.1 cm
<b>H Altura Muerta</b>	396	<b>Paquete 2 Ancho</b>	13 in / 33.02 cm
<b>D Depth</b>	440	<b>Paquete 1 Profundidad</b>	20 in / 50.8 cm
<b>1st Package Type</b>	Wood Crate	<b>Paquete 2 Profundidad</b>	8 in / 20.32 cm
<b>Peso Total (sin cable o cadena)</b>	64	<b>Paquete 1 Peso Neto</b>	72.16 lbs / 33 Kg
<b>2nd Package Type</b>	Wood Crate	<b>Paquete 2 Peso Neto</b>	62.48 lbs / 28 Kg
<b>Peso Total</b>	156.2 lbs / 71 Kg	<b>Paquete 1 Peso Bruto</b>	85.8 lbs / 39 Kg
		<b>Paquete 2 Peso Bruto</b>	70.4 lbs / 32 Kg

Referential Images / Imágenes Referenciales  
Specifications may change without notice / las especificaciones pueden cambiar sin previo aviso