

1/2 ton Electric Chain Hoist w/ Power Trolley 2 Speed 380V 3ø 50HZ 13ft G100 Nickel Duty H4/M5

Características Esenciales

- 3 Años de Garantía, Servicio y Atención al Cliente en Chile



Especificaciones Técnicas

Capacidad de Carga	1/2 ton	Radio Mínimo de Giro	1.3
Altura de Izaje Estandar (Customizable)	13 ft / 4 m	Normas	ASME HST-1 , ASME B30.16 , EN60204-37
Velocidad /min	ft @60Hz 9,5 mt @50Hz	Garantía	3 Year
Numero de Velocidades	2 Speed	Hoist UL Components	UL Listed Contactors
Voltaje	3 Phase 380V 50Hz	Hoist Motor Power in KW	0.75
Potencia Total Watts	1000	Hour Meter	Internal Working Hour Meter
Protección IEC Motor	IP55	Hoist Motor Insulation Grade	F
Tipo Transmisión / Reductor	Spur gearbox	Hoist Contactor Coil Voltage	48V
Tipo de Cadena	G100 Nikel	Hoist Contactors Amps	10A
Dimensiones de la Cadena	6.3mm	Hoist Contactor Brand	Schneider
Caidas de Cadena	1	IEC Hoist IP Protection	IP55
Longitud de cadena	13	IEC Pendant Control Protection	IP66
Humedad	20%~90%	Hoist Motor Brake Type and DC Voltage	DC170V
Temperatura	-4 ~ 104° F / -20 ~ 40° C		

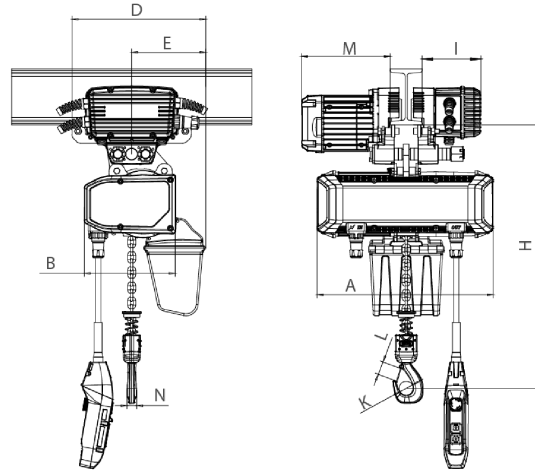

Rated load (t)	Type	Dimension (mm)							
		Minimum distance from the bottom of the track to the bottom hook: H	A	L	B	D	E	I	M
0.25	PWRXT0.25-01	473	440	3500-5500	285	210	20	105	140
0.5	PWRXT0.5-01	473	440		285	210	20	105	140

Peso & Dimensiones

H Altura Muerta	396	Paquete 1 Peso Neto	65.56 lbs / 30 Kg
J Boca Gancho	35	Paquete 2 Peso Neto	62.48 lbs / 28 Kg
A Altura Total	396	Paquete 1 Peso Bruto	79.2 lbs / 36 Kg
Peso Total (sin cable o cadena)	58	Paquete 2 Peso Bruto	70.4 lbs / 32 Kg
D Depth	440	Paquete 1 Profundidad	20 in / 50.8 cm
1st Package Type	Wood Crate	Paquete 2 Profundidad	8 in / 20.32 cm
W Ancho	305	Paquete 1 Ancho	15 in / 38.1 cm
2nd Package Type	Wood Crate	Paquete 2 Ancho	13 in / 33.02 cm
Peso Total	149.6 lbs / 68 Kg	Paquete 1 Altura	20 in / 50.8 cm
		Paquete 2 Altura	20 in / 50.8 cm

Detalles del Empaque

Referential Images / Imágenes Referenciales
Specifications may change without notice / las especificaciones pueden cambiar sin previo aviso