



1/2 ton Electric Chain Hoist w/ Power Trolley 1 Speed 380V 50HZ

Características Esenciales

- 3 Años de Garantía, Servicio y Atención al Cliente en Chile

Especificaciones Técnicas

Capacidad de Carga	1/2 ton	Tipo de Cadena	G100 Nikel
Altura de Izaje Estandar (Customizable)	13 ft / 4 m	Dimensiones de la Cadena	6.3mm
Velocidad /min	31.49 ft @60Hz 8 mt @50Hz	Caidas de Cadena	1
Numero de Velocidades	1 Speed	Longitud de cadena	13
Voltaje	3 Phase 380V 50Hz	Humedad	20%~90%
Potencia Total Watts	1000	Temperatura	-4 ~ 104° F / -20 ~ 40° C
Clase de Servicio	H4/M5/2m/Class D	Potencia del Trolley	500
Protección IEC Motor	IP55	Velocidad del Trolley /min	43.30 ft @60Hz 11 mt @50Hz
Control	Pendant Control IP66 and Optional Wireless	Cantidad de Velocidades	1
Voltaje del Control	48V	Normas	ASME HST-1 , ASME B30.16 , EN60204-37
Parada de Emergencia	Yes	Garantía	3 Year
Tipo Transmisión / Reductor	Spur gearbox		

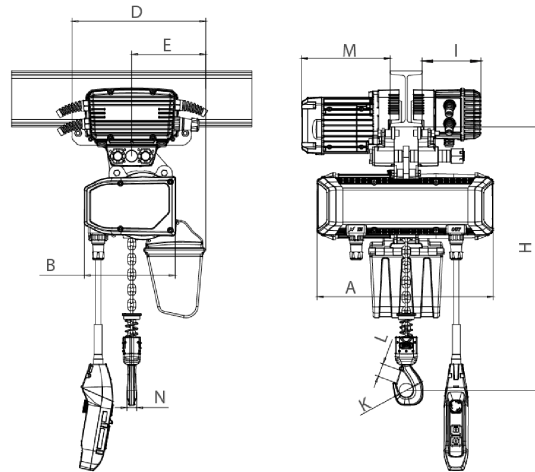

Rated load (t)	Type	Dimension (mm)							
		Minimum distance from the bottom of the track to the bottom hook: H	A	L	B	D	E	I	M
0.25	PWRXT0.25-01	473	440	3500-5500	285	210	20	105	140
0.5	PWRXT0.5-01	473	440		285	210	20	105	140

Peso & Dimensiones

H Altura Muerta	396	Paquete 1 Peso Neto	61.16 lbs / 28 Kg
W Ancho	305	Paquete 2 Peso Neto	62.48 lbs / 28 Kg
A Altura Total	396	Paquete 1 Peso Bruto	74.8 lbs / 34 Kg
J Boca Gancho	35	Paquete 2 Peso Bruto	70.4 lbs / 32 Kg
D Depth	440	Paquete 1 Profundidad	20 in / 50.8 cm
Peso Total (sin cable o cadena)	56	Paquete 2 Profundidad	8 in / 20.32 cm
Peso Total	145.2 lbs / 66 Kg	Paquete 1 Ancho	15 in / 38.1 cm

Detalles del Empaque

		Paquete 2 Ancho	13 in / 33.02 cm
		Paquete 1 Altura	20 in / 50.8 cm
		Paquete 2 Altura	20 in / 50.8 cm

Referential Images / Imágenes Referenciales
Specifications may change without notice / las especificaciones pueden cambiar sin previo aviso