

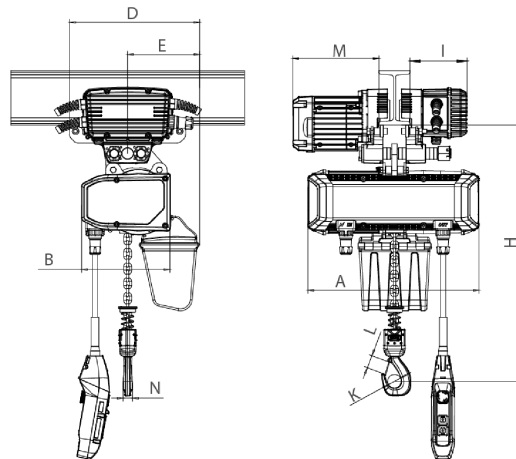

1/4 ton Electric Chain Hoist w/ Power Trolley Variable Speed 380V 3ø 50~60HZ

Especificaciones Técnicas

Capacidad de Carga	1/4 ton	Dimensiones de la Cadena	5mm
Altura de Izaje Estandar (Customizable)	13 ft / 4 m	Caidas de Cadena	1
Velocidad /min	ft @60Hz 1.5~9.6 mt @50Hz	Longitud de cadena	13 ft (4 m)
Numero de Velocidades	Variable Speed	Humedad	20%~90%
Voltaje	3 Phase 380V 50Hz	Temperatura	-4 ~ 104° F / -20 ~ 40° C
Potencia Total Watts	1500	Potencia del Trolley	250
Clase de Servicio	H4/M5/2m/Class D	Velocidad del Trolley /min	5.9~47.23 ft @60Hz 1.5~12 mt @50Hz
Protección IEC Motor	IP55	Cantidad de Velocidades	Variable
Tipo Transmisión / Reductor	Spur gearbox	Normas	ASME HST-1 , ASME B30.16 , EN60204-36
Tipo de Cadena	G100 Nikel		



Rated load (t)	Type	Dimension (mm)							
		Minimum distance from the bottom of the track to the bottom hook: H	A	L	B	D	E	I	M
0.25	PWRXT0.25-0 1	473	440	3500- 5500	285	210	20	105	140
0.5	PWRXT0.5-01	473	440		285	210	20	105	140

Peso & Dimensiones

H Altura Muerta	385
W Ancho	305
A Altura Total	385
J Boca Gancho	35
D Depth	440
Peso Total (sin cable o cadena)	67
Peso Total	156.2 lbs / 71 Kg

Detalles del Empaque

Paquete 1 Peso Neto	72.16 lbs / 33 Kg
Paquete 2 Peso Neto	62.48 lbs / 28 Kg
Paquete 1 Peso Bruto	85.8 lbs / 39 Kg
Paquete 2 Peso Bruto	70.4 lbs / 32 Kg
Paquete 1 Profundidad	20 in / 50.8 cm
Paquete 2 Profundidad	8 in / 20.32 cm
Paquete 1 Ancho	15 in / 38.1 cm
Paquete 2 Ancho	13 in / 33.02 cm
Paquete 1 Altura	20 in / 50.8 cm
Paquete 2 Altura	20 in / 50.8 cm