



1/4 ton Electric Chain Hoist w/ Power Trolley Variable Speed 220V 1ø 50~60HZ

Características Esenciales

- 3 Años de Garantía, Servicio y Atención al Cliente en Chile

Especificaciones Técnicas

Capacidad de Carga	1/4 ton	Longitud de cadena	13
Voltaje	1 Phase 220~240V 50/60Hz	Load Chain weight per foot [lbs]	0.36
Altura de Izaje Estandar (Customizable)	13 ft / 4 m	Humedad	20%~90%
Velocidad /min	ft @60Hz 1.5~9.6 mt @50Hz	Temperatura	-4 ~ 104° F / -20 ~ 40° C
Numero de Velocidades	Variable Speed	Tipo Transmisión / Reductor	Spur gearbox
Hoist VFD Power	1.5kW	Reducer Lubrication Type	Oil
Hoist VFD Brand	HUAYUAN	Paint Specifications	Electrostatic Sprayed Plastic (ESP) Epoxy resins, Polyester Resins, Barium, Pigments
VFD Model	Z230	Normas	ASME HST-1 , ASME B30.16 , EN60204-36
Brake Resistor Kw	0.3Kw	Standards Certified	CE
Clase de Servicio	H4/M5/2m/Class D	Potencia del Trolley	250
IEC Hoist IP Protection	IP55	Cantidad de Velocidades	Variable
Protección IEC Motor	IP55	Velocidad del Trolley /min	5.9~47.23 ft @60Hz 1.5~12 mt @50Hz
Pendant Control Yes No	Yes	Trolley Motor Brake Type and DC Voltage	DC170V
IEC Pendant Control Protection	IP66	Trolley Motor Insulation Grade	F
Pendant Control Emergency Stop	Yes	Trolley VFD Power in KW	2.5kW
Pendant Control total Length	10 ft	Trolley VFD Brand	Huayuan
Hoist Motor Power in KW	0.5	Trolley VFD Model	Z230
Hoist Motor Brake Type and DC Voltage	DC170V	Trolley Wheel Diameter	95
Hoist Motor Insulation Grade	F	Trolley Wheel Material	No. 45 steel
Potencia Total Watts	1500	Trolley Minimum Turn Radius	1.3
Power Cord Length and Phase Order	3 ft / Black L1, White, Green ground	Trolley Beam Range	3" to 5"
Recommended Hoist Protection Circuit Breaker AMPs and Type	Type D 10A	Trolley Beam Extension Kit	up to 12"
Optional Load Chain Brand & Country of Origin	FEC Japan	Overload Protection	Overload Motor Clutch
Tipo de Cadena	G100 Nikel	Hour Meter	Internal Working Hour Meter
Dimensiones de la Cadena	5mm	Brake SKU	PWRX-0.25-0.5-PN.4.11
Caidas de Cadena	1	Brake rectifiers-half-wave	PWRX-BKTF-HW

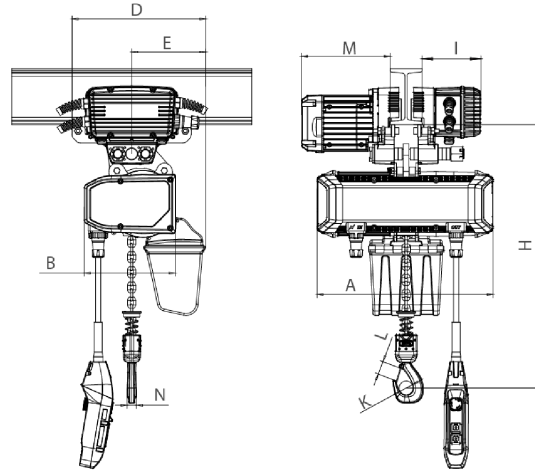

Rated load (t)	Type	Dimension (mm)									
		Minimum distance from the bottom of the track to the bottom hook: H	A	L	B	D	E	I	M	N	K
0.25-0.5	PWRXT0.25-0.5-VS	473	447	3500-5500	217	334	152	147	220	20	35

Peso & Dimensiones

A Altura Total	385	Paquete 1 Altura	20 in / 50.8 cm
J Boca Gancho	35	Paquete 2 Altura	20 in / 50.8 cm
W Ancho	305	Paquete 1 Ancho	15 in / 38.1 cm
H Altura Muerta	385	Paquete 2 Ancho	13 in / 33.02 cm
D Depth	440	Paquete 1 Profundidad	20 in / 50.8 cm
1st Package Type	Wood Crate	Paquete 2 Profundidad	8 in / 20.32 cm
Peso Total (sin cable o cadena)	67	Paquete 1 Peso Neto	72.16 lbs / 33 Kg
2nd Package Type	Wood Crate	Paquete 2 Peso Neto	62.48 lbs / 28 Kg
Peso Total	156.2 lbs / 71 Kg	Paquete 1 Peso Bruto	85.8 lbs / 39 Kg
		Paquete 2 Peso Bruto	70.4 lbs / 32 Kg

Detalles del Empaque

Referential Images / Imágenes Referenciales
Specifications may change without notice / las especificaciones pueden cambiar sin previo aviso