



## 1/4 ton Electric Chain Hoist w/ Power Trolley Variable Speed 110V 1ø 60HZ

### Características Esenciales

- 3 Años de Garantía, Servicio y Atención al Cliente en Chile

## Especificaciones Técnicas

Trolley Motor Insulation Grade	F	VFD Model	Z230
Trolley Beam Extension Kit	up to 12"	Brake Resistor Kw	0.3Kw
Trolley Beam Range	3" to 5"	Brake SKU	PWRX-0.25-0.5-PN.4.11
Trolley Minimum Turn Radius	1.3	Brake rectifiers-half-wave	PWRX-BKTF-HW
Trolley Motor Brake Type and DC Voltage	DC170V	Optional Load Chain Brand & Country of Origin	FEC Japan
Standards Certified	CE	Overload Protection	Overload Motor Clutch
Trolley VFD Brand	Huayuan	Paint Specifications	Electrostatic Sprayed Plastic (ESP) Epoxy resins, Polyester Resins, Barium, Pigments
Trolley VFD Model	Z230	Pendant Control Emergency Stop	Yes
Trolley VFD Power in KW	2.5kW	Pendant Control Yes No	Yes
Trolley Wheel Diameter	95	Power Cord Length and Phase Order	3 ft / Black L1, White, Green ground
Trolley Wheel Material	No. 45 steel	Recommended Hoist Protection Circuit Breaker AMPS and Type	Type D 10A

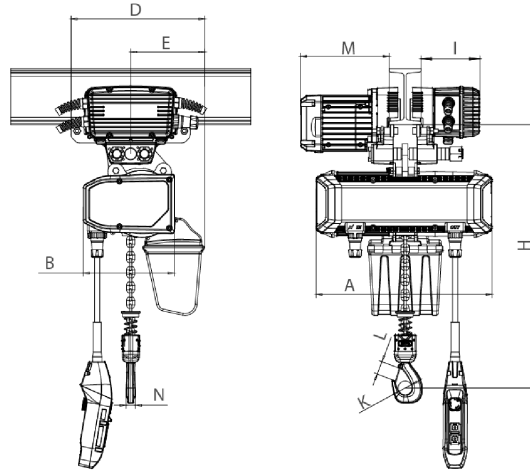

Rated load (t)	Type	Dimension (mm)									
		Minimum distance from the bottom of the track to the bottom hook: H	A	L	B	D	E	I	M	N	K
0.25-0.5	PWRXT0.25-0.5-VS	473	447	3500-5500	217	334	152	147	220	20	35

## Peso & Dimensiones

**Peso Total**

156.2 lbs / 71 Kg

Referential Images / Imágenes Referenciales  
 Specifications may change without notice / las especificaciones pueden cambiar sin previo aviso