



1/4 ton Electric Chain Hoist w/ Power Trolley 1 Speed 208~240V / 440~480V 3Å, 60HZ

Características Esenciales

- 3 Años de Garantía, Servicio y Atención al Cliente en Chile

Especificaciones Técnicas

Capacidad de Carga	1/4 ton	Load Chain weight per foot [lbs]	0.36
Voltaje	3 Phase 208~240/440~480V 50/60Hz	Humedad	20%~90%
Altura de Izaje Estandar (Customizable)	13 ft / 4 m	Temperatura	-4 ~ 104° F / -20 ~ 40° C
Velocidad /min	37.79 ft @60Hz 9.6 mt @50Hz	Tipo Transmisión / Reductor	Spur gearbox
Numero de Velocidades	1 Speed	Reducer Lubrication Type	Oil
Hoist Contactors Amps	10A	Paint Specifications	Electrostatic Sprayed Plastic (ESP) Epoxy resins, Polyester Resins, Barium, Pigments
Hoist Contactor Brand	Schneider	Normas	ASME HST-1 , ASME B30.16 , EN60204-36
Hoist UL Components	UL Listed Contactors	Standards Certified	CE
Hoist Contactor Coil Voltage	48V	Potencia del Trolley	250
Clase de Servicio	H4/M5/2m/Class D	Cantidad de Velocidades	1
IEC Hoist IP Protection	IP55	Velocidad del Trolley /min	43.30 ft @60Hz 11 mt @50Hz
Protección IEC Motor	IP55	Trolley Motor Brake Type and DC Voltage	DC99V/DC207V
Pendant Control Yes No	Yes	Trolley Motor Insulation Grade	F
IEC Pendant Control Protection	IP66	Trolley Contactors Amps	20A
Pendant Control Emergency Stop	Yes	Trolley Contactors Brand	Schneider
Pendant Control total Length	10 ft	Trolley Contactors Coil Voltage	48V
Hoist Motor Power in KW	0.5	Trolley Wheel Diameter	95
Hoist Motor Brake Type and DC Voltage	DC99V/DC207V	Trolley Wheel Material	No. 45 steel
Hoist Motor Insulation Grade	F	Trolley Minimum Turn Radius	1.3
Potencia Total Watts	750	Trolley Beam Range	3" to 5"
Power Cord Length and Phase Order	3 ft / Black L1 , Red L2 and Blue L3□Green ground	Trolley Beam Extension Kit	up to 12"
Recommended Hoist Protection Circuit Breaker AMPs and Type	Type D 15A at 220V and 10A at 460V	Overload Protection	Overload Motor Clutch
Optional Load Chain Brand & Country of Origin	FEC Japan	Hour Meter	Internal Working Hour Meter
Tipo de Cadena	G100 Nikel	Brake SKU	PWRX-0.25-0.5-PN.4.11
Dimensiones de la Cadena	5mm	Brake rectifiers-half-wave	PWRX-BKTF-HW
Caidas de Cadena	1	Brake rectifiers-full-wave	PWRX-BKTF-FW
Longitud de cadena	13		

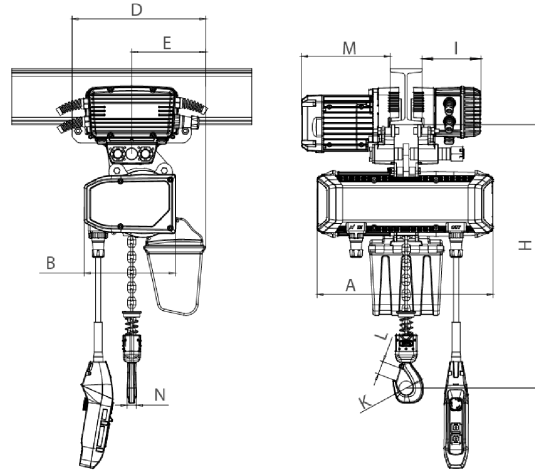

Rated load (t)	Type	Dimension (mm)									
		Minimum distance from the bottom of the track to the bottom hook: H	A	L	B	D	E	I	M	N	K
0.25-0.5	PWRXT0.25-0.5-VS	473	447	3500-5500	217	334	152	147	220	20	35

Peso & Dimensiones

A Altura Total	385	Paquete 1 Altura	20 in / 50.8 cm
J Boca Gancho	35	Paquete 2 Altura	20 in / 50.8 cm
W Ancho	305	Paquete 1 Ancho	15 in / 38.1 cm
H Altura Muerta	385	Paquete 2 Ancho	13 in / 33.02 cm
D Depth	440	Paquete 1 Profundidad	20 in / 50.8 cm
1st Package Type	Wood Crate	Paquete 2 Profundidad	8 in / 20.32 cm
Peso Total (sin cable o cadena)	56	Paquete 1 Peso Neto	61.16 lbs / 28 Kg
2nd Package Type	Wood Crate	Paquete 2 Peso Neto	62.48 lbs / 28 Kg
Peso Total	145.2 lbs / 66 Kg	Paquete 1 Peso Bruto	74.8 lbs / 34 Kg
		Paquete 2 Peso Bruto	70.4 lbs / 32 Kg

Referential Images / Imágenes Referenciales
Specifications may change without notice / las especificaciones pueden cambiar sin previo aviso