



7.5 ton Electric Chain Hoist Variable Speed 380V 3ø 50~60HZ

Características Esenciales

- 3 Años de Garantía, Servicio y Atención al Cliente en Chile

Especificaciones Técnicas

Capacidad de Carga	7.5 ton	Caidas de Cadena	3
Altura de Izaje Estandar (Customizable)	30 ft / 9 m	Longitud de cadena	90
Velocidad /min	ft @60Hz 0.3~1.8 mt @50Hz	Humedad	20%~90%
Numero de Velocidades	Variable Speed	Temperatura	-4 ~ 104° F / -20 ~ 40° C
Voltaje	3 Phase 380V 50Hz	Normas	ASME HST-1 , ASME B30.16 , EN60204-37
Potencia Total Watts	4000	Garantía	3 Year
Clase de Servicio	H4/M5/2m/Class D	Hoist VFD Power	4kW
Protección IEC Motor	IP55	Hoist VFD Brand	HUAYUAN
Control	Pendant Control IP66 and Optional Wireless	Hoist Motor Power in KW	3
Voltaje del Control	24V	Hour Meter	Internal Working Hour Meter
Parada de Emergencia	Yes	Hoist Motor Insulation Grade	F
Tipo Transmisión / Reductor	Spur gearbox	IEC Hoist IP Protection	IP55
Tipo de Cadena	G100 Nikel	IEC Pendant Control Protection	IP66
Dimensiones de la Cadena	11.2 mm	Hoist Motor Brake Type and DC Voltage	DC170V

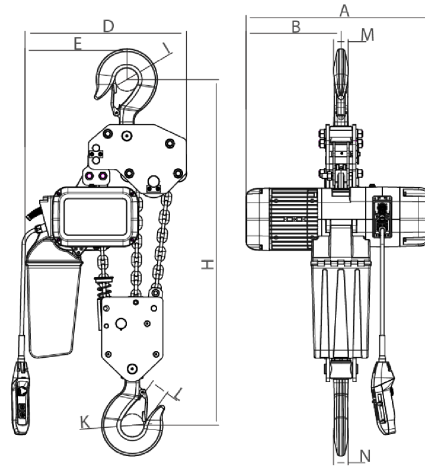

[Size list: mm]

Rated load (t)	Type	Minimum distance between hooks: H	A	B	D	E	I	M	N	K	L
7	PWRXF7-03	1170	695	350	420	265	45	20	34	59	48

Peso & Dimensiones

H Altura Muerta	1170	Paquete 1 Peso Neto	294.8 lbs / 134 Kg
J Boca Gancho	85	Paquete 1 Ancho	20 in / 50.8 cm
A Altura Total	1020	Paquete 1 Peso Bruto	495 lbs / 225 Kg
Peso Total (sin cable o cadena)	130	Paquete 1 Altura	31 in / 78.74 cm
D Depth	681	Paquete 1 Profundidad	30 in / 76.2 cm
1st Package Type	Wood Crate		
W Ancho	576		
Peso Total	495 lbs / 225 Kg		

Detalles del Empaque

Referential Images / Imágenes Referenciales

Specifications may change without notice / las especificaciones pueden cambiar sin previo aviso