

## 7.5 ton Electric Chain Hoist Variable Speed 440~480V 3Ø 50~60HZ

### Características Esenciales

- 3 Años de Garantía, Servicio y Atención al Cliente en Chile

### Especificaciones Técnicas

Capacidad de Carga	7.5 ton	Caidas de Cadena	3
Altura de Izaje Estandar (Customizable)	30 ft / 9 m	Longitud de cadena	90
Velocidad /min	1.1~7 ft @60Hz mt @50Hz	Humedad	20%~90%
Numero de Velocidades	Variable Speed	Temperatura	-4 ~ 104° F / -20 ~ 40° C
Voltaje	3 Phase 440~480V 60Hz	Normas	ASME HST-1 , ASME B30.16 , EN60204-37
Potencia Total Watts	4000	Garantía	3 Year
Clase de Servicio	H4/M5/2m/Class D	Hoist VFD Power	4kW
Protección IEC Motor	IP55	Hoist VFD Brand	HUAYUAN
Control	Pendant Control IP66 and Optional Wireless	Hoist Motor Power in KW	3
Voltaje del Control	24V	Hour Meter	Internal Working Hour Meter
Parada de Emergencia	Yes	Hoist Motor Insulation Grade	F
Tipo Transmisión / Reductor	Spur gearbox	IEC Hoist IP Protection	IP55
Tipo de Cadena	G100 Nikel	IEC Pendant Control Protection	IP66
Dimensiones de la Cadena	11.2 mm	Hoist Motor Brake Type and DC Voltage	DC207V

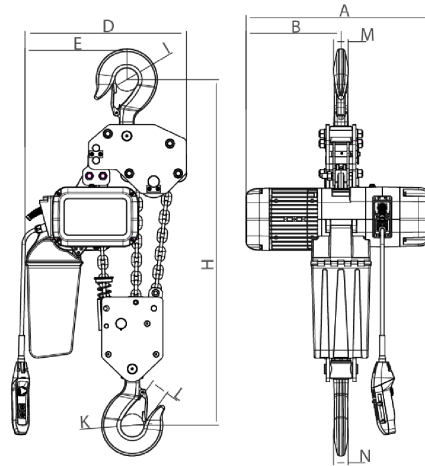

[Size list: mm]

Rated load (t)	Type	Minimum distance between hooks: H	A	B	D	E	I	M	N	K	L
7	PWRXF7-03	1170	695	350	420	265	45	20	34	59	48

## Peso & Dimensiones

<b>H Altura Muerta</b>	1170
<b>J Boca Gancho</b>	85
<b>A Altura Total</b>	1020
<b>Peso Total (sin cable o cadena)</b>	130
<b>D Depth</b>	681
<b>1st Package Type</b>	Wood Crate
<b>W Ancho</b>	576
<b>Peso Total</b>	495 lbs / 225 Kg

## Detalles del Empaque

<b>Paquete 1 Peso Neto</b>	294.8 lbs / 134 Kg
<b>Paquete 1 Ancho</b>	20 in / 50.8 cm
<b>Paquete 1 Peso Bruto</b>	495 lbs / 225 Kg
<b>Paquete 1 Altura</b>	31 in / 78.74 cm
<b>Paquete 1 Profundidad</b>	30 in / 76.2 cm

Referential Images / Imágenes Referenciales  
Specifications may change without notice / las especificaciones pueden cambiar sin previo aviso