



5 ton Electric Chain Hoist Variable Speed 440~480V 3φ^{1/2} 50~60HZ

Características Esenciales

- 3 Años de Garantía, Servicio y Atención al Cliente en Chile

Especificaciones Técnicas

Capacidad de Carga	5 ton	Power Cord Length and Phase Order	3 ft / Black L1 , Red L2 and Blue L3 Green ground
Voltaje	3 Phase 440~480V 60Hz	Recommended Hoist Protection Circuit Breaker AMPs and Type	Type D 20A
Altura de Izaje Estandar (Customizable)	30 ft / 9 m	Optional Load Chain Brand & Country of Origin	FEC Japan
Velocidad /min	1.5~10.6 ft @60Hz mt @50Hz	Tipo de Cadena	G100 Nikel
Numero de Velocidades	Variable Speed	Dimensiones de la Cadena	11.2 mm
Hoist VFD Power	4kW	Caidas de Cadena	2
Hoist VFD Brand	HUAYUAN	Longitud de cadena	60
VFD Model	Z230	Load Chain weight per foot [lbs]	1.83
Brake Resistor Kw	1Kw	Humedad	20%~90%
Clase de Servicio	H4/M5/2m/Class D	Temperatura	-4 ~ 104° F / -20 ~ 40° C
IEC Hoist IP Protection	IP55	Tipo Transmisión / Reductor	Spur gearbox
Protección IEC Motor	IP55	Reducer Lubrication Type	Oil
Pendant Control Yes No	Yes	Paint Specifications	Electrostatic Sprayed Plastic (ESP) Epoxy resins, Polyester Resins, Barium, Pigments
IEC Pendant Control Protection	IP66	Normas	ASME HST-1 , ASME B30.16 , EN60204-36
Pendant Control Emergency Stop	Yes	Standards Certified	CE
Pendant Control total Length	27 ft	Overload Protection	Overload Motor Clutch
Hoist Motor Power in KW	3	Hour Meter	Internal Working Hour Meter
Hoist Motor Brake Type and DC Voltage	DC207V	Brake SKU	PWRX-2-20-PN.60.61
Hoist Motor Insulation Grade	F	Brake rectifiers-half-wave	PWRX-BKTF-HW
Potencia Total Watts	4000		

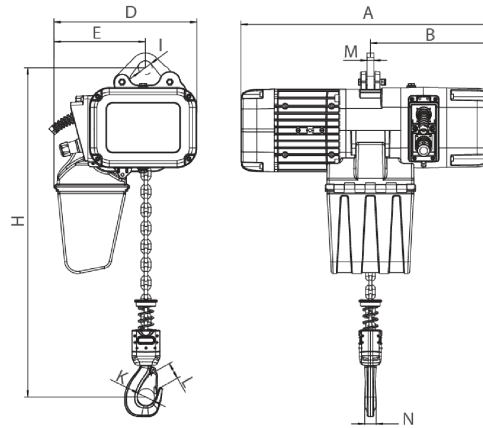

[Size list: mm]

Rated load (t)	Type	Minimum distance between hooks: H	A	B	D	E	I	M	N	K	L
1	PWRXF1-01	455	590	276	330	210	32	16	25	42	32
2	PWRXF2-01	550	590	276	330	210	38	20	35	52	42
3	PWRXF3-01	560	695	350	420	265	45	20	34	59	48
5	PWRXF5-02	675	695	350	420	307	55	28	44	60	48

Peso & Dimensiones

A Altura Total	675
J Boca Gancho	60
W Ancho	420
H Altura Muerta	810
D Depth	695
1st Package Type	Wood Crate
Peso Total (sin cable o cadena)	185
Peso Total	495 lbs / 225 Kg

Detalles del Empaque

Paquete 1 Altura	31 in / 78.74 cm
Paquete 1 Peso Neto	294.8 lbs / 134 Kg
Paquete 1 Ancho	20 in / 50.8 cm
Paquete 1 Peso Bruto	495 lbs / 225 Kg
Paquete 1 Profundidad	30 in / 76.2 cm

Referential Images / Imágenes Referenciales
 Specifications may change without notice / las especificaciones pueden cambiar sin previo aviso

