



5 ton Electric Chain Hoist 2 Speed 575V -10% 3Ø 50/60HZ

Características Esenciales

- 3 Años de Garantía, Servicio y Atención al Cliente en Chile

Especificaciones Técnicas

Capacidad de Carga	5 ton	Power Cord Length and Phase Order	3 ft / Red L1, White L2 and Black L3, Green ground
Voltaje	3 Phase 575v 50/60hz	Recommended Hoist Protection Circuit Breaker AMPs and Type	Type D 20A
Altura de Izaje Estandar (Customizable)	30 ft / 9 m	Optional Load Chain Brand & Country of Origin	FEC Japan
Velocidad /min	3.1/10.6 ft @60Hz 0.8/2.7 mt @50Hz	Tipo de Cadena	G100 Nikel
Numero de Velocidades	2 Speed	Dimensiones de la Cadena	11.2 mm
Hoist Contactors Amps	25A	Caidas de Cadena	2
Hoist Contactor Brand	Schneider	Longitud de cadena	60
Hoist Contactor Coil Voltage	24 V	Load Chain weight per foot [lbs]	1.83
Clase de Servicio	H4/M5/2m/Class D	Humedad	20%~90%
IEC Hoist IP Protection	IP55	Temperatura	-4 ~ 104° F / -20 ~ 40° C
Protección IEC Motor	IP55	Tipo Transmisión / Reductor	Spur gearbox
Pendant Control Yes No	Yes	Reducer Lubrication Type	Oil
IEC Pendant Control Protection	IP66	Paint Specifications	Electrostatic Sprayed Plastic (ESP) Epoxy resins, Polyester Resins, Barium, Pigments
Pendant Control Emergency Stop	Yes	Normas	ASME HST-1 , ASME B30.16 , EN60204-36
Pendant Control total Length	27 ft	Standards Certified	CE
Hoist Motor Power in KW	3	Overload Protection	Overload Motor Clutch
Hoist Motor Brake Type and DC Voltage	DC260V	Hour Meter	Internal Working Hour Meter
Hoist Motor Insulation Grade	F	Brake SKU	PWRX-2-20-PN.60.61
Potencia Total Watts	3000	Brake rectifiers-half-wave	PWRX-BKTF-HW

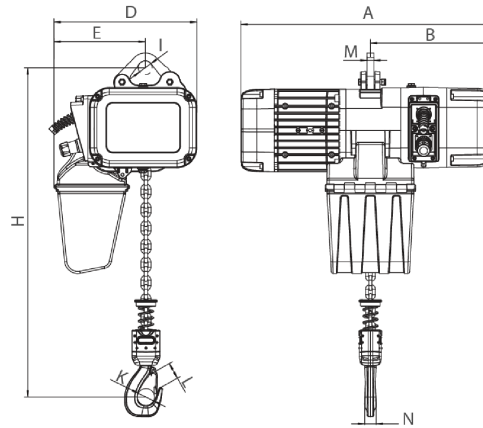

[Size list: mm]

Rated load (t)	Type	Minimum distance between hooks: H	A	B	D	E	I	M	N	K	L
1	PWRXF1-01	455	590	276	330	210	32	16	25	42	32
2	PWRXF2-01	550	590	276	330	210	38	20	35	52	42
3	PWRXF3-01	560	695	350	420	265	45	20	34	59	48
5	PWRXF5-02	675	695	350	420	307	55	28	44	60	48

Peso & Dimensiones

A Altura Total	675
J Boca Gancho	60
W Ancho	420
H Altura Muerta	810
D Depth	695
1st Package Type	Wood Crate
Peso Total (sin cable o cadena)	185
Peso Total	495 lbs / 225 Kg

Detalles del Empaque

Paquete 1 Altura	31 in / 78.74 cm
Paquete 1 Peso Neto	294.8 lbs / 134 Kg
Paquete 1 Ancho	20 in / 50.8 cm
Paquete 1 Peso Bruto	495 lbs / 225 Kg
Paquete 1 Profundidad	30 in / 76.2 cm

Referential Images / Imágenes Referenciales
Specifications may change without notice / las especificaciones pueden cambiar sin previo aviso

