



5 ton Electric Chain Hoist 2 Speed 380V 3ø 50HZ 30ft G100 Nickel Duty H4/M5

Características Esenciales

- 3 Años de Garantía, Servicio y Atención al Cliente en Chile

Especificaciones Técnicas

Capacidad de Carga	5 ton	Parada de Emergencia	Yes
Altura de Izaje Estandar (Customizable)	30 ft / 9 m	Tipo Transmisión / Reductor	Spur gearbox
Velocidad /min	3.1/10.6 ft @60Hz 0.8/2.7 mt @50Hz	Tipo de Cadena	G100 Nickel
Numero de Velocidades	2 Speed	Dimensiones de la Cadena	11.2 mm
Voltaje	3 Phase 380V 50Hz	Caidas de Cadena	2
Potencia Total Watts	3000	Longitud de cadena	60
Clase de Servicio	H4/M5/2m/Class D	Humedad	20%~90%
Protección IEC Motor	IP55	Temperatura	-4 ~ 104° F / -20 ~ 40° C
Control	Pendant Control IP66 and Optional Wireless	Normas	ASME HST-1 , ASME B30.16 , EN60204-36
Voltaje del Control	24V	Garantía	3 Year

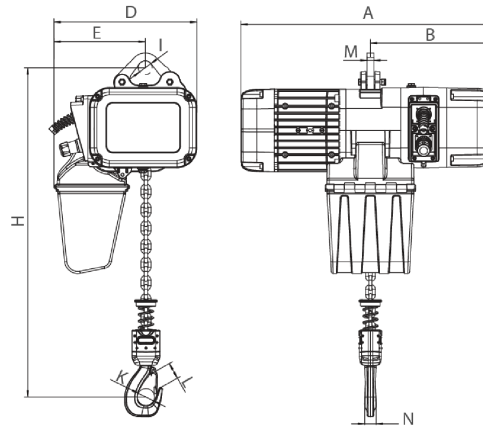

[Size list: mm]

Rated load (t)	Type	Minimum distance between hooks: H	A	B	D	E	I	M	N	K	L
1	PWRXF1-01	455	590	276	330	210	32	16	25	42	32
2	PWRXF2-01	550	590	276	330	210	38	20	35	52	42
3	PWRXF3-01	560	695	350	420	265	45	20	34	59	48
5	PWRXF5-02	675	695	350	420	307	55	28	44	60	48

Peso & Dimensiones

H Altura Muerta	810	Paquete 1 Peso Neto	294.8 lbs / 134 Kg
W Ancho	420	Paquete 1 Ancho	20 in / 50.8 cm
A Altura Total	675	Paquete 1 Peso Bruto	495 lbs / 225 Kg
J Boca Gancho	60	Paquete 1 Altura	31 in / 78.74 cm
D Depth	695	Paquete 1 Profundidad	30 in / 76.2 cm
Peso Total (sin cable o cadena)	185		
Peso Total	495 lbs / 225 Kg		

Detalles del Empaque

Referential Images / Imágenes Referenciales

Specifications may change without notice / las especificaciones pueden cambiar sin previo aviso