



5 ton Electric Chain Hoist 2 Speed 208~240V / 440~480V 3ø 60HZ

Características Esenciales

- 3 Años de Garantía, Servicio y Atención al Cliente en Chile

Especificaciones Técnicas

Paint Specifications	Electrostatic Sprayed Plastic (ESP) Epoxy resins, Polyester Resins, Barium, Pigments	Clase de Servicio	H4/M5/2m/Class D
Standards Certified	CE	Protección IEC Motor	IP55
Optional Load Chain Brand & Country of Origin	FEC Japan	Control	Pendant Control IP66 and Optional Wireless
Recommended Hoist Protection Circuit Breaker AMPs and Type	Type D 25A at 220V and 20A at 460V	Voltaje del Control	24V
Power Cord Length and Phase Order	3 ft / Black L1 , Red L2 and Blue L3 Green ground	Parada de Emergencia	Yes
Brake rectifiers-half-wave	PWRX-BKTF-HW	Hoist Contactor Brand	Schneider
Brake SKU	PWRX-2-20-PN.60.61	Tipo Transmisión / Reductor	Spur gearbox
Overload Protection	Overload Motor Clutch	Tipo de Cadena	G100 Nikel
Pendant Control Emergency Stop	Yes	Dimensiones de la Cadena	11.2 mm
Pendant Control Yes No	Yes	Caidas de Cadena	2
Capacidad de Carga	5 ton	Longitud de cadena	60
Altura de Izaje Estandar (Customizable)	30 ft / 9 m	Humedad	20%~90%
Velocidad /min	10.63 ft @60Hz 2.70 mt @50Hz	Temperatura	-4 ~ 104° F / -20 ~ 40° C
Numero de Velocidades	2 Speed	Normas	ASME HST-1 , ASME B30.16 , EN60204-36
Voltaje	3 Phase 208~240/440~480V 50/60Hz	Garantía	3 Year
Potencia Total Watts	3000		

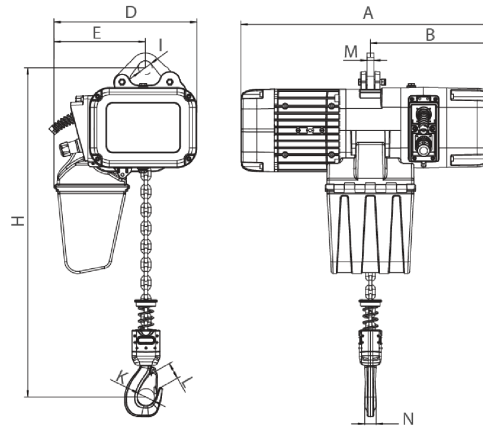

[Size list: mm]

Rated load (t)	Type	Minimum distance between hooks: H	A	B	D	E	I	M	N	K	L
1	PWRXF1-01	455	590	276	330	210	32	16	25	42	32
2	PWRXF2-01	550	590	276	330	210	38	20	35	52	42
3	PWRXF3-01	560	695	350	420	265	45	20	34	59	48
5	PWRXF5-02	675	695	350	420	307	55	28	44	60	48

Peso & Dimensiones

H Altura Muerta	810	Paquete 1 Peso Neto	294.8 lbs / 134 Kg
W Ancho	420	Paquete 1 Ancho	20 in / 50.8 cm
A Altura Total	675	Paquete 1 Peso Bruto	495 lbs / 225 Kg
J Boca Gancho	60	Paquete 1 Altura	31 in / 78.74 cm
D Depth	695	Paquete 1 Profundidad	30 in / 76.2 cm
Peso Total (sin cable o cadena)	185		
Peso Total	495 lbs / 225 Kg		

Detalles del Empaque

Referential Images / Imágenes Referenciales

Specifications may change without notice / las especificaciones pueden cambiar sin previo aviso