



5 ton Electric Chain Hoist 1 Speed 208~240V / 440~480V 3ø 60HZ 30ft G100 Nickel Duty H4/M5

Características Esenciales

- 3 Años de Garantía, Servicio y Atención al Cliente en Chile

Especificaciones Técnicas

Capacidad de Carga	5 ton	Longitud de cadena	60
Altura de Izaje Estandar (Customizable)	30 ft / 9 m	Humedad	20%~90%
Velocidad /min	10.63 ft @60Hz 2.70 mt @50Hz	Temperatura	-4 ~ 104° F / -20 ~ 40° C
Numero de Velocidades	1 Speed	Normas	ASME HST-1 , ASME B30.16 , EN60204-36
Voltaje	3 Phase 208~240/440~480V 50/60Hz	Garantía	3 Year
Potencia Total Watts	3000	Hoist UL Components	UL Listed Contactors
Clase de Servicio	H4/M5/2m/Class D	Hoist Motor Power in KW	3
Protección IEC Motor	IP55	Hour Meter	Internal Working Hour Meter
Control	Pendant Control IP66 and Optional Wireless	Hoist Motor Insulation Grade	F
Voltaje del Control	24V	Hoist Contactor Coil Voltage	24 V
Parada de Emergencia	Yes	Hoist Contactors Amps	25A
Tipo Transmisión / Reductor	Spur gearbox	Hoist Contactor Brand	Schneider
Tipo de Cadena	G100 Nikel	IEC Hoist IP Protection	IP55
Dimensiones de la Cadena	11.2 mm	IEC Pendant Control Protection	IP66
Caidas de Cadena	2	Hoist Motor Brake Type and DC Voltage	DC99V/DC207V

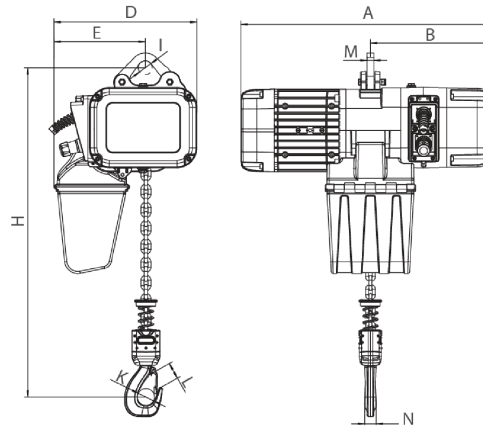

[Size list: mm]

Rated load (t)	Type	Minimum distance between hooks: H	A	B	D	E	I	M	N	K	L
1	PWRXF1-01	455	590	276	330	210	32	16	25	42	32
2	PWRXF2-01	550	590	276	330	210	38	20	35	52	42
3	PWRXF3-01	560	695	350	420	265	45	20	34	59	48
5	PWRXF5-02	675	695	350	420	307	55	28	44	60	48

Peso & Dimensiones

H Altura Muerta	810
J Boca Gancho	60
A Altura Total	675
Peso Total (sin cable o cadena)	185
D Depth	695
1st Package Type	Wood Crate
W Ancho	420
Peso Total	319 lbs / 145 Kg

Detalles del Empaque

Paquete 1 Peso Neto	294.8 lbs / 134 Kg
Paquete 1 Ancho	20 in / 50.8 cm
Paquete 1 Peso Bruto	319 lbs / 145 Kg
Paquete 1 Altura	31 in / 78.74 cm
Paquete 1 Profundidad	30 in / 76.2 cm

Referential Images / Imágenes Referenciales
Specifications may change without notice / las especificaciones pueden cambiar sin previo aviso

