



3 ton Electric Chain Hoist Variable Speed 380V 3ø 50~60HZ

Características Esenciales

- 3 Años de Garantía, Servicio y Atención al Cliente en Chile

Especificaciones Técnicas

Capacidad de Carga	3 ton	Hoist Motor Insulation Grade	F
Voltaje	3 Phase 380V 50Hz	Potencia Total Watts	4000
Altura de Izaje Estandar (Customizable)	30 ft / 9 m	Power Cord Length and Phase Order	3 ft / Red L1, White L2 and Black L3, Green ground
Velocidad /min	ft @60Hz 0.7~5.4 mt @50Hz	Recommended Hoist Protection Circuit Breaker AMPs and Type	Type D 20A
Numero de Velocidades	Variable Speed	Optional Load Chain Brand & Country of Origin	FEC Japan
Hoist VFD Power	4kW	Tipo de Cadena	G100 Nikel
Hoist VFD Brand	HUAYUAN	Dimensiones de la Cadena	11.2 mm
VFD Model	Z230	Caidas de Cadena	1
Brake Resistor Kw	1Kw	Longitud de cadena	30
Clase de Servicio	H4/M5/2m/Class D	Load Chain weight per foot [lbs]	1.83
IEC Hoist IP Protection	IP55	Humedad	20%~90%
Protección IEC Motor	IP55	Temperatura	-4 ~ 104° F / -20 ~ 40° C
Pendant Control Yes No	Yes	Tipo Transmisión / Reductor	Spur gearbox
IEC Pendant Control Protection	IP66	Reducer Lubrication Type	Oil
Pendant Control Emergency Stop	Yes	Paint Specifications	Electrostatic Sprayed Plastic (ESP) Epoxy resins, Polyester Resins, Barium, Pigments
Pendant Control total Length	27 ft	Normas	ASME HST-1 , ASME B30.16 , EN60204-35
Hoist Motor Power in KW	3	Standards Certified	CE

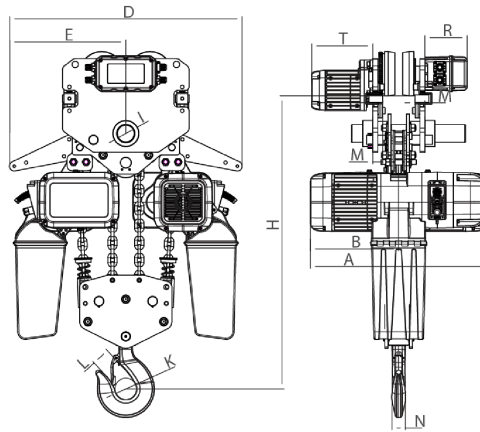

Rated load (t)	Type	Dimension (mm)												
		Minimum distance from the bottom of the track to the bottom hook: H	A	L	B	D	E	I	M	N	K	L	T	R
10	PWRXT10-04	1045	700	3500-5500	350	920	460	70	39	48	85	80	242	167

Peso & Dimensiones

A Altura Total	560
J Boca Gancho	59
W Ancho	420
H Altura Muerta	645
D Depth	695
1st Package Type	Wood Crate
Peso Total (sin cable o cadena)	130
Peso Total	330 lbs / 150 Kg

Detalles del Empaque

Paquete 1 Altura	31 in / 78.74 cm
Paquete 1 Peso Neto	184.8 lbs / 84 Kg
Paquete 1 Ancho	20 in / 50.8 cm
Paquete 1 Peso Bruto	330 lbs / 150 Kg
Paquete 1 Profundidad	30 in / 76.2 cm

Referential Images / Imágenes Referenciales
Specifications may change without notice / las especificaciones pueden cambiar sin previo aviso