



3 ton Electric Chain Hoist Variable Speed 110V 1ø 60HZ

Características Esenciales

- 3 Años de Garantía, Servicio y Atención al Cliente en Chile

Especificaciones Técnicas

Capacidad de Carga	3 ton	Power Cord Length and Phase Order	3 ft / Black L1, White, Green ground
Voltaje	1 Phase 110~120V 60Hz	Recommended Hoist Protection Circuit Breaker AMPs and Type	Type D 20A
Altura de Izaje Estandar (Customizable)	30 ft / 9 m	Optional Load Chain Brand & Country of Origin	FEC Japan
Velocidad /min	ft @60Hz 0.7~5.4 mt @50Hz	Tipo de Cadena	G100 Nikel
Numero de Velocidades	Variable Speed	Dimensiones de la Cadena	11.2 mm
Hoist VFD Power	4kW	Caidas de Cadena	1
Hoist VFD Brand	HUAYUAN	Longitud de cadena	30
VFD Model	Z230	Load Chain weight per foot [lbs]	1.83
Brake Resistor Kw	1Kw	Humedad	20%~90%
Clase de Servicio	H4/M5/2m/Class D	Temperatura	-4 ~ 104° F / -20 ~ 40° C
IEC Hoist IP Protection	IP55	Tipo Transmisión / Reductor	Spur gearbox
Protección IEC Motor	IP55	Reducer Lubrication Type	Oil
Pendant Control Yes No	Yes	Paint Specifications	Electrostatic Sprayed Plastic (ESP) Epoxy resins, Polyester Resins, Barium, Pigments
IEC Pendant Control Protection	IP66	Normas	ASME HST-1 , ASME B30.16 , EN60204-35
Pendant Control Emergency Stop	Yes	Standards Certified	CE
Pendant Control total Length	27 ft	Overload Protection	Overload Motor Clutch
Hoist Motor Power in KW	3	Hour Meter	Internal Working Hour Meter
Hoist Motor Brake Type and DC Voltage	DC170V	Brake SKU	PWRX-2-20-PN.60.61
Hoist Motor Insulation Grade	F	Brake rectifiers-half-wave	PWRX-BKTF-HW
Potencia Total Watts	4000		

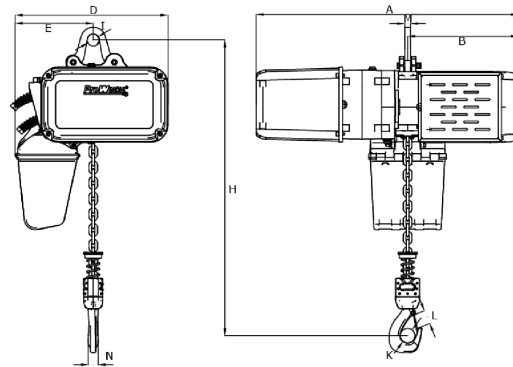

[Size list: mm]

Rated load (t)	Type	Minimum distance between hooks: H	A	B	D	E	I	M	N	K	L
1	PWRXF1-VS-110V	499	704.5	298	410	209	31	24	25	42	32
2-3	PWRXF2-3-VS-110V	540	780	348	463	263	45	20	35	52	42

Peso & Dimensiones

A Altura Total	560
J Boca Gancho	59
W Ancho	420
H Altura Muerta	645
D Depth	695
1st Package Type	Wood Crate
Peso Total (sin cable o cadena)	130
Peso Total	330 lbs / 150 Kg

Detalles del Empaque

Paquete 1 Altura	31 in / 78.74 cm
Paquete 1 Peso Neto	184.8 lbs / 84 Kg
Paquete 1 Ancho	20 in / 50.8 cm
Paquete 1 Peso Bruto	330 lbs / 150 Kg
Paquete 1 Profundidad	30 in / 76.2 cm

Referential Images / Imágenes Referenciales
Specifications may change without notice / las especificaciones pueden cambiar sin previo aviso

