



3 ton Electric Chain Hoist 1 Speed 380V 3ø 50HZ

Características Esenciales

- 3 Años de Garantía, Servicio y Atención al Cliente en Chile

Especificaciones Técnicas

Capacidad de Carga	3 ton	Longitud de cadena	30
Altura de Izaje Estandar (Customizable)	30 ft / 9 m	Humedad	20%~90%
Velocidad /min	21.26 ft @60Hz 5.40 mt @50Hz	Temperatura	-4 ~ 104° F / -20 ~ 40° C
Numero de Velocidades	1 Speed	Normas	ASME HST-1 , ASME B30.16 , EN60204-35
Voltaje	3 Phase 380V 50Hz	Garantía	3 Year
Potencia Total Watts	3000	Hoist Motor Power in KW	3
Clase de Servicio	H4/M5/2m/Class D	Hour Meter	Internal Working Hour Meter
Protección IEC Motor	IP55	Hoist Motor Insulation Grade	F
Control	Pendant Control IP66 and Optional Wireless	Hoist Contactor Coil Voltage	24 V
Voltaje del Control	24V	Hoist Contactors Amps	18A
Parada de Emergencia	Yes	Hoist Contactor Brand	Schneider
Tipo Transmisión / Reductor	Spur gearbox	IEC Hoist IP Protection	IP55
Tipo de Cadena	G100 Nikel	IEC Pendant Control Protection	IP66
Dimensiones de la Cadena	11.2 mm	Hoist Motor Brake Type and DC Voltage	DC170V
Caidas de Cadena	1		

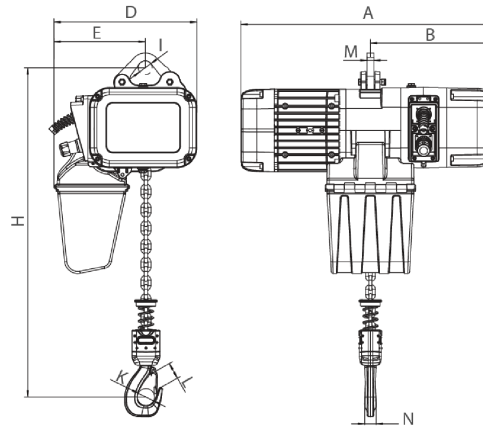

[Size list: mm]

Rated load (t)	Type	Minimum distance between hooks: H	A	B	D	E	I	M	N	K	L
1	PWRXF1-01	455	590	276	330	210	32	16	25	42	32
2	PWRXF2-01	550	590	276	330	210	38	20	35	52	42
3	PWRXF3-01	560	695	350	420	265	45	20	34	59	48
5	PWRXF5-02	675	695	350	420	307	55	28	44	60	48

Peso & Dimensiones

H Altura Muerta	645
J Boca Gancho	59
A Altura Total	560
Peso Total (sin cable o cadena)	140
D Depth	695
1st Package Type	Wood Crate
W Ancho	420
Peso Total	209 lbs / 95 Kg

Detalles del Empaque

Paquete 1 Peso Neto	184.8 lbs / 84 Kg
Paquete 1 Ancho	20 in / 50.8 cm
Paquete 1 Peso Bruto	209 lbs / 95 Kg
Paquete 1 Altura	31 in / 78.74 cm
Paquete 1 Profundidad	30 in / 76.2 cm

Referential Images / Imágenes Referenciales
Specifications may change without notice / las especificaciones pueden cambiar sin previo aviso

