



3 ton Electric Chain Hoist 1 Speed 208~240V / 440~480V 3ph 60HZ

Características Esenciales

- 3 Años de Garantía, Servicio y Atención al Cliente en Chile

3 ton Electric Chain Hoist 1 Speed 208~240V / 440~480V 3ph 60HZ

Especificaciones Técnicas

Capacidad de Carga	3 ton	Power Cord Length and Phase Order	3 ft / Black L1 , Red L2 and Blue L3 Green ground
Voltaje	3 Phase 208~240/440~480V 50/60Hz	Recommended Hoist Protection Circuit Breaker AMPs and Type	Type D 25A at 220V and 20A at 460V
Altura de Izaje Estandar (Customizable)	30 ft / 9 m	Optional Load Chain Brand & Country of Origin	FEC Japan
Velocidad /min	21.25 ft @60Hz 5.40 mt @50Hz	Tipo de Cadena	G100 Nikel
Numero de Velocidades	1 Speed	Dimensiones de la Cadena	11.2 mm
Hoist Contactors Amps	25A	Caidas de Cadena	1
Hoist Contactor Brand	Schneider	Longitud de cadena	30
Hoist UL Components	UL Listed Contactors	Load Chain weight per foot [lbs]	1.83
Hoist Contactor Coil Voltage	24 V	Humedad	20%~90%
Clase de Servicio	H4/M5/2m/Class D	Temperatura	-4 ~ 104° F / -20 ~ 40° C
IEC Hoist IP Protection	IP55	Tipo Transmisión / Reductor	Spur gearbox
Protección IEC Motor	IP55	Reducer Lubrication Type	Oil
Pendant Control Yes No	Yes	Paint Specifications	Electrostatic Sprayed Plastic (ESP) Epoxy resins, Polyester Resins, Barium, Pigments
IEC Pendant Control Protection	IP66	Normas	ASME HST-1 , ASME B30.16 , EN60204-35
Pendant Control Emergency Stop	Yes	Standards Certified	CE
Pendant Control total Length	27 ft	Overload Protection	Overload Motor Clutch
Hoist Motor Power in KW	3	Hour Meter	Internal Working Hour Meter
Hoist Motor Brake Type and DC Voltage	DC99V/DC207V	Brake SKU	PWRX-2-20-PN.60.61
Hoist Motor Insulation Grade	F	Brake rectifiers-half-wave	PWRX-BKTF-HW
Potencia Total Watts	3000	Brake rectifiers-full-wave	PWRX-BKTF-FW

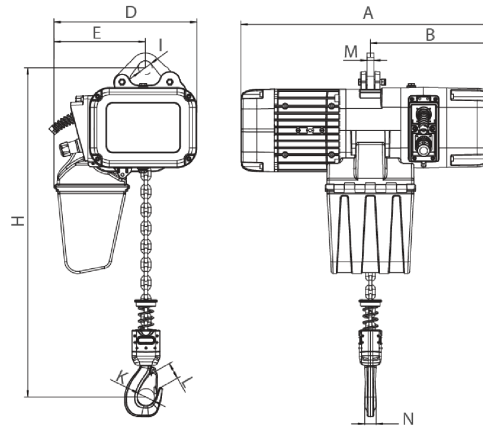

[Size list: mm]

Rated load (t)	Type	Minimum distance between hooks: H	A	B	D	E	I	M	N	K	L
1	PWRXF1-01	455	590	276	330	210	32	16	25	42	32
2	PWRXF2-01	550	590	276	330	210	38	20	35	52	42
3	PWRXF3-01	560	695	350	420	265	45	20	34	59	48
5	PWRXF5-02	675	695	350	420	307	55	28	44	60	48

Peso & Dimensiones

A Altura Total	560	Paquete 1 Altura	31 in / 78.74 cm
J Boca Gancho	59	Paquete 1 Peso Neto	184.8 lbs / 84 Kg
W Ancho	420	Paquete 1 Ancho	20 in / 50.8 cm
H Altura Muerta	645	Paquete 1 Peso Bruto	209 lbs / 95 Kg
D Depth	695	Paquete 1 Profundidad	30 in / 76.2 cm
1st Package Type	Wood Crate		
Peso Total (sin cable o cadena)	130		
Peso Total	209 lbs / 95 Kg		

Detalles del Empaque

Referential Images / Imágenes Referenciales
Specifications may change without notice / las especificaciones pueden cambiar sin previo aviso

