



## 20 ton Electric Chain Hoist 1 Speed 380V 3ø 50HZ

### Características Esenciales

- 3 Años de Garantía, Servicio y Atención al Cliente en Chile

### Especificaciones Técnicas

Brake SKU	PWRX-2-20-PN.60.61	Clase de Servicio	H4/M5/2m/Class D
Brake rectifiers-half-wave	PWRX-BKTF-HW	Protección IEC Motor	IP55
Power Cord Length and Phase Order	3 ft / Red L1, White L2 and Black L3, Green ground	Control	Pendant Control IP66 and Optional Wireless
Recommended Hoist Protection Circuit Breaker AMPs and Type	Type D 30A	Voltaje del Control	24V
Optional Load Chain Brand & Country of Origin	FEC Japan	Parada de Emergencia	Yes
Overload Protection	Overload Motor Clutch	Hoist Contactor Brand	Schneider
Pendant Control Yes No	Yes	Tipo Transmisión / Reductor	Spur gearbox
Standards Certified	CE	Tipo de Cadena	G100 Nikel
Paint Specifications	Electrostatic Sprayed Plastic (ESP) Epoxy resins, Polyester Resins, Barium, Pigments	Dimensiones de la Cadena	11.2 mm
Pendant Control Emergency Stop	Yes	Caidas de Cadena	8
Capacidad de Carga	20 ton	Longitud de cadena	320
Altura de Izaje Estandar (Customizable)	40 ft / 12 m	Humedad	20%~90%
Velocidad /min	5.31 ft @60Hz 1.35 mt @50Hz	Temperatura	-4 ~ 104° F / -20 ~ 40° C
Numero de Velocidades	1 Speed	Normas	ASME HST-1 , ASME B30.16 , EN60204-39
Voltaje	3 Phase 380V 50Hz	Garantía	3 Year
Potencia Total Watts	6000		

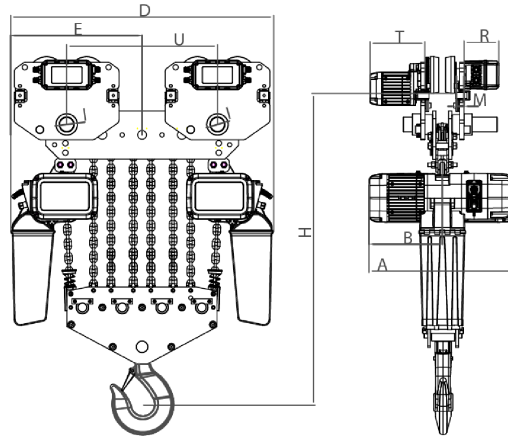

Rated load (t)	Type	Dimension (mm)												
		Minimum distance from the bottom of the track to the bottom hook: H	A	L	B	D	E	I	M	N	K	L	T	R
20	PWRXT20-08	1300	700	3500-5500	350	1246	623	71	40	80	120	96	242	167

## Peso & Dimensiones

<b>H Altura Muerta</b>	1240	<b>Paquete 1 Peso Neto</b>	1430 lbs / 649 Kg
<b>W Ancho</b>	1250	<b>Paquete 1 Ancho</b>	30 in / 76.2 cm
<b>A Altura Total</b>	1270	<b>Paquete 1 Peso Bruto</b>	1474 lbs / 669 Kg
<b>J Boca Gancho</b>	120	<b>Paquete 1 Altura</b>	51 in / 129.54 cm
<b>D Depth</b>	700	<b>Paquete 1 Profundidad</b>	55 in / 139.7 cm
<b>Peso Total (sin cable o cadena)</b>	845		
<b>Peso Total</b>	1474 lbs / 669 Kg		

## Detalles del Empaque

Referential Images / Imágenes Referenciales

Specifications may change without notice / las especificaciones pueden cambiar sin previo aviso