

## 20 ton Electric Chain Hoist 1 Speed 208~240V / 440~480V 3Ø 60HZ

### Características Esenciales

- 3 Años de Garantía, Servicio y Atención al Cliente en Chile

### Especificaciones Técnicas

Capacidad de Carga	20 ton	Longitud de cadena	320
Altura de Izaje Estandar (Customizable)	40 ft / 12 m	Humedad	20%~90%
Velocidad /min	5.31 ft @60Hz 1.35 mt @50Hz	Temperatura	-4 ~ 104° F / -20 ~ 40° C
Numero de Velocidades	1 Speed	Normas	ASME HST-1 , ASME B30.16 , EN60204-39
Voltaje	3 Phase 208~240/440~480V 50/60Hz	Garantía	3 Year
Potencia Total Watts	6000	Hoist UL Components	UL Listed Contactors
Clase de Servicio	H4/M5/2m/Class D	Hoist Motor Power in KW	3+3
Protección IEC Motor	IP55	Hour Meter	Internal Working Hour Meter
Control	Pendant Control IP66 and Optional Wireless	Hoist Motor Insulation Grade	F
Voltaje del Control	24V	Hoist Contactor Coil Voltage	24 V
Parada de Emergencia	Yes	Hoist Contactors Amps	25A
Tipo Transmisión / Reductor	Spur gearbox	Hoist Contactor Brand	Schneider
Tipo de Cadena	G100 Nikel	IEC Hoist IP Protection	IP55
Dimensiones de la Cadena	11.2 mm	IEC Pendant Control Protection	IP66
Caidas de Cadena	8	Hoist Motor Brake Type and DC Voltage	DC99V/DC207V

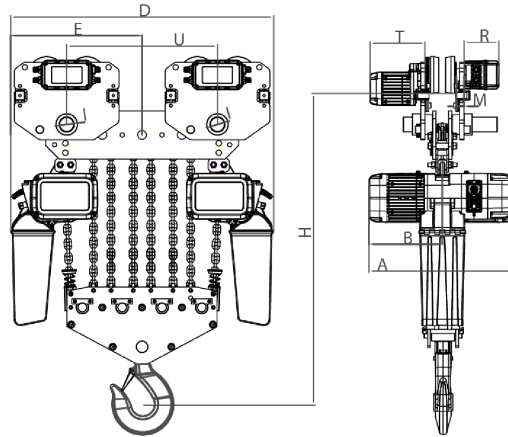

Rated load (t)	Type	Dimension (mm)												
		Minimum distance from the bottom of the track to the bottom hook: H	A	L	B	D	E	I	M	N	K	L	T	R
20	PWRXT20-08	1300	700	3500-5500	350	1246	623	71	40	80	120	96	242	167

## Peso & Dimensiones

<b>H Altura Muerta</b>	1240	<b>Paquete 1 Peso Neto</b>	1430 lbs / 649 Kg
<b>J Boca Gancho</b>	120	<b>Paquete 1 Ancho</b>	30 in / 76.2 cm
<b>A Altura Total</b>	1270	<b>Paquete 1 Peso Bruto</b>	1474 lbs / 669 Kg
<b>Peso Total (sin cable o cadena)</b>	845	<b>Paquete 1 Altura</b>	51 in / 129.54 cm
<b>D Depth</b>	700	<b>Paquete 1 Profundidad</b>	55 in / 139.7 cm
<b>1st Package Type</b>	Wood Crate		
<b>W Ancho</b>	1250		
<b>Peso Total</b>	1474 lbs / 669 Kg		

## Detalles del Empaque

Referential Images / Imágenes Referenciales  
Specifications may change without notice / las especificaciones pueden cambiar sin previo aviso