



## 2 ton Electric Chain Hoist Variable Speed 380V 3ø 50~60HZ

### Características Esenciales

- 3 Años de Garantía, Servicio y Atención al Cliente en Chile

### Especificaciones Técnicas

|   |  |                                       |                                       |
|---|--|---------------------------------------|---------------------------------------|
| Capacidad de Carga                      | 2 ton                                      | Caidas de Cadena                      | 1                                     |
| Altura de Izaje Estandar (Customizable) | 20 ft / 6 m                                | Longitud de cadena                    | 20                                    |
| Velocidad /min                          | ft @60Hz<br>0.8~6.8 mt @50Hz               | Humedad                               | 20%~90%                               |
| Numero de Velocidades                   | Variable Speed                             | Temperatura                           | -4 ~ 104° F / -20 ~ 40° C             |
| Voltaje                                 | 3 Phase 380V 50Hz                          | Normas                                | ASME HST-1 , ASME B30.16 , EN60204-34 |
| Potencia Total Watts                    | 4000                                       | Garantía                              | 3 Year                                |
| Clase de Servicio                       | H4/M5/2m/Class D                           | Hoist VFD Power                       | 4kW                                   |
| Protección IEC Motor                    | IP55                                       | Hoist VFD Brand                       | HUAYUAN                               |
| Control                                 | Pendant Control IP66 and Optional Wireless | Hoist Motor Power in KW               | 3                                     |
| Voltaje del Control                     | 24V  | Hour Meter                            | Internal Working Hour Meter           |
| Parada de Emergencia                    | Yes  | Hoist Motor Insulation Grade          | F                                     |
| Tipo Transmisión / Reductor             | Spur gearbox                               | IEC Hoist IP Protection               | IP55                                  |
| Tipo de Cadena                          | G100 Nikel                                 | IEC Pendant Control Protection        | IP66                                  |
| Dimensiones de la Cadena                | 10 mm                                      | Hoist Motor Brake Type and DC Voltage | DC170V                                |

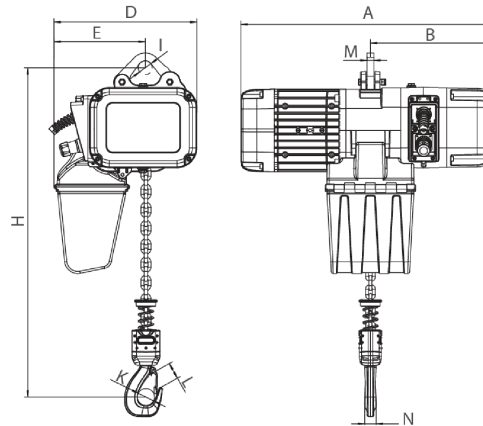

[Size list: mm]

| Rated load (t) | Type      | Minimum distance between hooks: H | A   | B   | D   | E   | I  | M  | N  | K  | L  |
|----------------|-----------|-----------------------------------|-----|-----|-----|-----|----|----|----|----|----|
| 1              | PWRXF1-01 | 455                               | 590 | 276 | 330 | 210 | 32 | 16 | 25 | 42 | 32 |
| 2              | PWRXF2-01 | 550                               | 590 | 276 | 330 | 210 | 38 | 20 | 35 | 52 | 42 |
| 3              | PWRXF3-01 | 560                               | 695 | 350 | 420 | 265 | 45 | 20 | 34 | 59 | 48 |
| 5              | PWRXF5-02 | 675                               | 695 | 350 | 420 | 307 | 55 | 28 | 44 | 60 | 48 |

## Peso & Dimensiones

|  |                  |
|--|------------------|
| <b>H Altura Muerta</b>                 | 600              |
| <b>J Boca Gancho</b>                   | 52               |
| <b>A Altura Total</b>                  | 540              |
| <b>Peso Total (sin cable o cadena)</b> | 155              |
| <b>D Depth</b>                         | 695              |
| <b>1st Package Type</b>                | Wood Crate       |
| <b>W Ancho</b>                         | 420              |
| <b>Peso Total</b>                      | 308 lbs / 140 Kg |

## Detalles del Empaque

|                              |                   |
|------------------------------|-------------------|
| <b>Paquete 1 Peso Neto</b>   | 184.8 lbs / 84 Kg |
| <b>Paquete 1 Ancho</b>       | 20 in / 50.8 cm   |
| <b>Paquete 1 Peso Bruto</b>  | 308 lbs / 140 Kg  |
| <b>Paquete 1 Altura</b>      | 31 in / 78.74 cm  |
| <b>Paquete 1 Profundidad</b> | 30 in / 76.2 cm   |

Referential Images / Imágenes Referenciales  
Specifications may change without notice / las especificaciones pueden cambiar sin previo aviso

