



2 ton Electric Chain Hoist Variable Speed 440~480V 3Ø 50~60HZ

Características Esenciales

- 3 Años de Garantía, Servicio y Atención al Cliente en Chile

Especificaciones Técnicas

Capacidad de Carga	2 ton	Caidas de Cadena	1
Altura de Izaje Estandar (Customizable)	20 ft / 6 m	Longitud de cadena	20
Velocidad /min	3.1~26.7 ft @60Hz mt @50Hz	Humedad	20%~90%
Numero de Velocidades	Variable Speed	Temperatura	-4 ~ 104° F / -20 ~ 40° C
Voltaje	3 Phase 440~480V 60Hz	Normas	ASME HST-1 , ASME B30.16 , EN60204-34
Potencia Total Watts	4000	Garantía	3 Year
Clase de Servicio	H4/M5/2m/Class D	Hoist VFD Power	4kW
Protección IEC Motor	IP55	Hoist VFD Brand	HUAYUAN
Control	Pendant Control IP66 and Optional Wireless	Hoist Motor Power in KW	3
Voltaje del Control	24V	Hour Meter	Internal Working Hour Meter
Parada de Emergencia	Yes	Hoist Motor Insulation Grade	F
Tipo Transmisión / Reductor	Spur gearbox	IEC Hoist IP Protection	IP55
Tipo de Cadena	G100 Nikel	IEC Pendant Control Protection	IP66
Dimensiones de la Cadena	10 mm	Hoist Motor Brake Type and DC Voltage	DC207V

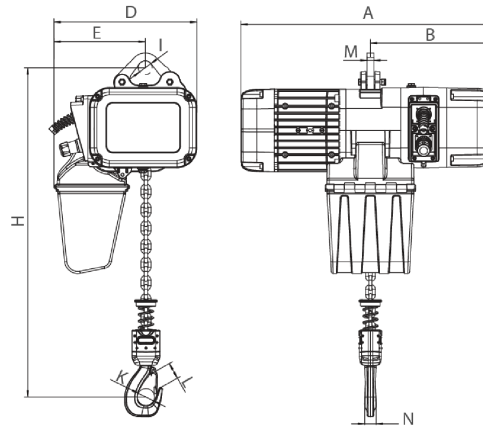

[Size list: mm]

Rated load (t)	Type	Minimum distance between hooks: H	A	B	D	E	I	M	N	K	L
1	PWRXF1-01	455	590	276	330	210	32	16	25	42	32
2	PWRXF2-01	550	590	276	330	210	38	20	35	52	42
3	PWRXF3-01	560	695	350	420	265	45	20	34	59	48
5	PWRXF5-02	675	695	350	420	307	55	28	44	60	48

Peso & Dimensiones

H Altura Muerta	600
J Boca Gancho	52
A Altura Total	540
Peso Total (sin cable o cadena)	155
D Depth	695
1st Package Type	Wood Crate
W Ancho	420
Peso Total	308 lbs / 140 Kg

Detalles del Empaque

Paquete 1 Peso Neto	184.8 lbs / 84 Kg
Paquete 1 Ancho	20 in / 50.8 cm
Paquete 1 Peso Bruto	308 lbs / 140 Kg
Paquete 1 Altura	31 in / 78.74 cm
Paquete 1 Profundidad	30 in / 76.2 cm

Referential Images / Imágenes Referenciales
 Specifications may change without notice / las especificaciones pueden cambiar sin previo aviso

