



## 2 ton Electric Chain Hoist 2 Speed 575V 3ø 50/60HZ 20ft G100 Nickel Duty H4/M5

### Características Esenciales

- 3 Años de Garantía, Servicio y Atención al Cliente en Chile

### Especificaciones Técnicas

Capacidad de Carga	2 ton	Parada de Emergencia	Yes
Altura de Izaje Estandar (Customizable)	20 ft / 6 m	Tipo Transmisión / Reductor	Spur gearbox
Velocidad /min	8.7/26.7 ft @60Hz 2.2/6.8 mt @50Hz	Tipo de Cadena	G100 Níkel
Numero de Velocidades	2 Speed	Dimensiones de la Cadena	10 mm
Voltaje	3 Phase 575v 50/60 Hz	Caidas de Cadena	1
Potencia Total Watts	3000	Longitud de cadena	20
Clase de Servicio	H4/M5/2m/Class D	Humedad	20%~90%
Protección IEC Motor	IP55	Temperatura	-4 ~ 104° F / -20 ~ 40° C
Control	Pendant Control IP66 and Optional Wireless	Normas	ASME HST-1 , ASME B30.16 , EN60204-34
Voltaje del Control	24V	Garantía	3 Year

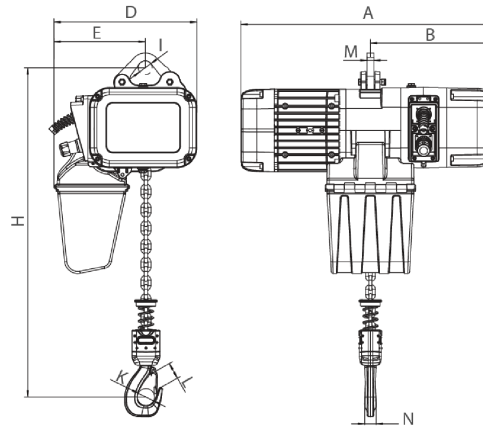

[Size list: mm]

Rated load (t)	Type	Minimum distance between hooks: H	A	B	D	E	I	M	N	K	L
1	PWRXF1-01	455	590	276	330	210	32	16	25	42	32
2	PWRXF2-01	550	590	276	330	210	38	20	35	52	42
3	PWRXF3-01	560	695	350	420	265	45	20	34	59	48
5	PWRXF5-02	675	695	350	420	307	55	28	44	60	48

## Peso & Dimensiones

<b>H Altura Muerta</b>	600	<b>Paquete 1 Peso Neto</b>	184.8 lbs / 84 Kg
<b>W Ancho</b>	420	<b>Paquete 1 Ancho</b>	20 in / 50.8 cm
<b>A Altura Total</b>	540	<b>Paquete 1 Peso Bruto</b>	308 lbs / 140 Kg
<b>J Boca Gancho</b>	52	<b>Paquete 1 Altura</b>	31 in / 78.74 cm
<b>D Depth</b>	695	<b>Paquete 1 Profundidad</b>	30 in / 76.2 cm
<b>Peso Total (sin cable o cadena)</b>	155		
<b>Peso Total</b>	308 lbs / 140 Kg		

## Detalles del Empaque

Referential Images / Imágenes Referenciales

Specifications may change without notice / las especificaciones pueden cambiar sin previo aviso