



2 ton Electric Chain Hoist 1 Speed 380V 3ø 50HZ

Características Esenciales

- 3 Años de Garantía, Servicio y Atención al Cliente en Chile

Especificaciones Técnicas

Capacidad de Carga	2 ton	Power Cord Length and Phase Order	3 ft / Red L1, White L2 and Black L3, Green ground
Voltaje	3 Phase 380V 50Hz	Recommended Hoist Protection Circuit Breaker AMPs and Type	Type D 20A
Altura de Izaje Estandar (Customizable)	20 ft / 6 m	Optional Load Chain Brand & Country of Origin	FEC Japan
Velocidad /min	26.77 ft @60Hz 6.80 mt @50Hz	Tipo de Cadena	G100 Nikel
Numero de Velocidades	1 Speed	Dimensiones de la Cadena	10 mm
Hoist Contactors Amps	18A	Caidas de Cadena	1
Hoist Contactor Brand	Schneider	Longitud de cadena	20
Hoist Contactor Coil Voltage	24 V	Load Chain weight per foot [lbs]	0.74
Clase de Servicio	H4/M5/2m/Class D	Humedad	20%~90%
IEC Hoist IP Protection	IP55	Temperatura	-4 ~ 104° F / -20 ~ 40° C
Protección IEC Motor	IP55	Tipo Transmisión / Reductor	Spur gearbox
Pendant Control Yes No	Yes	Reducer Lubrication Type	Oil
IEC Pendant Control Protection	IP66	Paint Specifications	Electrostatic Sprayed Plastic (ESP) Epoxy resins, Polyester Resins, Barium, Pigments
Pendant Control Emergency Stop	Yes	Normas	ASME HST-1 , ASME B30.16 , EN60204-34
Pendant Control total Length	17 ft	Standards Certified	CE
Hoist Motor Power in KW	3	Overload Protection	Overload Motor Clutch
Hoist Motor Brake Type and DC Voltage	DC170V	Hour Meter	Internal Working Hour Meter
Hoist Motor Insulation Grade	F	Brake SKU	PWRX-2-20-PN.60.61
Potencia Total Watts	3000	Brake rectifiers-half-wave	PWRX-BKTF-HW

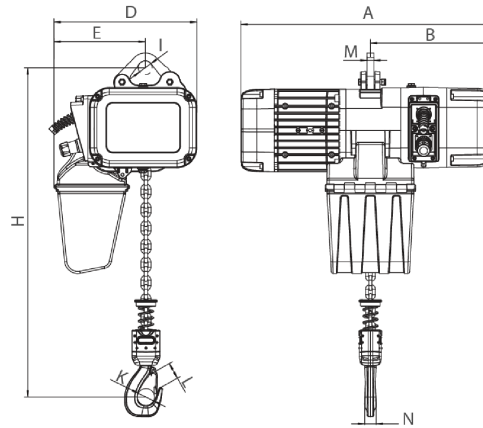

[Size list: mm]

Rated load (t)	Type	Minimum distance between hooks: H	A	B	D	E	I	M	N	K	L
1	PWRXF1-01	455	590	276	330	210	32	16	25	42	32
2	PWRXF2-01	550	590	276	330	210	38	20	35	52	42
3	PWRXF3-01	560	695	350	420	265	45	20	34	59	48
5	PWRXF5-02	675	695	350	420	307	55	28	44	60	48

Peso & Dimensiones

A Altura Total	540	Paquete 1 Altura	31 in / 78.74 cm
J Boca Gancho	52	Paquete 1 Peso Neto	184.8 lbs / 84 Kg
W Ancho	420	Paquete 1 Ancho	20 in / 50.8 cm
H Altura Muerta	600	Paquete 1 Peso Bruto	209 lbs / 95 Kg
D Depth	695	Paquete 1 Profundidad	30 in / 76.2 cm
1st Package Type	Wood Crate		
Peso Total (sin cable o cadena)	170		
Peso Total	209 lbs / 95 Kg		

Detalles del Empaque

Referential Images / Imágenes Referenciales
Specifications may change without notice / las especificaciones pueden cambiar sin previo aviso

